

TECHNICAL MANUAL - EN

MAQUET
GETINGE GROUP

X'TEN



Copyright

All rights reserved. This document may not be copied, adapted or translated without prior written permission, except as permitted under copyright law.

© Copyright MAQUET SAS

Subject to technical changes.

The illustrations and technical specifications provided in this manual may, on account of future product developments, differ slightly from the actual product supplied.





5 April 2017 | Ed04



CONTENTS

Symbols used in this manual		4
Quality standards compliance		5
Certification of MAQUET SAS's quality system		5
CE marking		5
1 General specifications		6
1.1 Specifications of X'TEN lights (serial no. < 20,000)		6
1.2 Specifications of X'TEN lights (serial no. > 20,000)		7
2 Cleaning, Disinfection and Sterilisation		8
2.1 Cleaning and disinfecting the surgical light		8
2.2 Cleaning and sterilising the handles		9
3 General maintenance		11
3.1 First-level maintenance		11
3.2 Yearly maintenance		12
3.3 Battery capacity test		18
4 Maintenance procedures		19
4.1 Removing the handle		19
4.2 Removing the underside		19
4.3 Removing grip handles		19
4.4 Removing right and left condensers		19
4.5 Removing the central filter		20
4.6 Removing the fixed mirror S/A		20
4.7 Removing the mobile mirror S/A		20
4.8 Removing the control rod		21
4.9 Removing the cam		21
4.10 Removing the wiring loom		21
5 Maintenance kits		22
6 Spare parts and consumables		25
7 Maintenance tools (OPM)		25
8 Diagrams and parts lists		26
9 Circuit diagrams		53
9.1 Standard lighthouse wiring		53
9.2 Lighthouse wiring with ambient lighting		54
9.3 Lighthouse video wiring		55
9.4 Ambient lighting control switch		56
10 Troubleshooting		57
11 Energix control box		58
11.1 Article part numbers		58
11.2 Description/characteristics		62
11.3 Settings		72
11.4 Navigation in menus and adjusting settings		73
11.5 Batteries		80
12 Troubleshooting the WPS		81
Checking list		85

SYMBOLS USED IN THIS MANUAL

Symbols	Meaning
	Mandatory May pose a threat to patient or user safety
	Recommendation Risk of damage to device or accessories
	CE labelling The device bears the CE mark and complies with the requirements of European directive 93/42/EEC relating to medical devices.
	Medical equipment Classified with respect to electric shock, fire and mechanical hazards, in accordance with UL 60601-1, IEC 60601-2-41 and CSA C22.2 No. 601-90-M90. 601-M90

QUALITY STANDARDS COMPLIANCE

CERTIFICATION OF MAQUET SAS'S QUALITY SYSTEM

LNE/G-MED certifies that the quality system developed by MAQUET SAS for design, implementation, sales, installation and after-sales service of surgical lights complies with the requirements of the following international standards:

- ISO 9001 (2008)
- ISO 13485 (2004).

CE MARKING

Compliance with the requirements of European Directive 93/42/EEC dated 14 June 1993 relating to medical devices was assessed as described in Annex VII of the Directive. X'TEN surgical lights belong to Class I as described in Annex IX of Directive 93/42/EEC.

1 GENERAL CHARACTERISTICS

(IN ACCORDANCE WITH STANDARDS IEC 60601-2-41 AND IEC 60601-1)

1.1 SPECIFICATIONS OF X'TEN LIGHTS (SERIAL NO. > 20,000)

Specifications	Unit	XTEN	
Main light			
Standard illumination	lx	110,000 ± 15%	
Diameter d10	cm (inches)	29 (11.4")	
Diameter d50	cm (inches)	18 (7")	
Illumination depth	cm (inches)	> 100 (39.4")	
Colour temperature (Ra)	K	3,500 ± 10%	
Colour rendering index	N/A	93 ± 5	
Shadow dilution	With one mask	%	85
	With two masks	%	47
	At base of tube	%	94
	With one mask, at base of tube	%	84
	With two masks, at base of tube	%	46
Radiant energy	mW.m ⁻² .lx ⁻¹	4.75	
Ambient light			
Illumination	lux	< 500	
Other specifications			
Electrical class	–	Class I	
Protection rating against a hazardous inflow of water	–	Ordinary	
Protection rating against electrical shocks	–	No parts applied	
Sterilisation and disinfection methods	–	See User's manual	
Operating mode	–	Continuous service	

Note:

- The values given with tolerances are guaranteed on the date of purchase of the product.
- The values given without tolerances have been measured by an authorised body on a production sample.

1.2 SPECIFICATIONS OF X'TEN LIGHTS (SERIAL NO. > 20,000)

Specifications	Unit	XTEN	
Main light			
Standard illumination (Ec)	lx	130,000 ± 15%	
Diameter d10	cm (inches)	26 (10.2") ± 10%	
Diameter d50	cm (inches)	15 (5.9") ± 10%	
Illumination depth 20%	cm (inches)	100 (39.4")	
Illumination depth 60%	cm (inches)	50 (19.7") ±10	
Colour temperature (Ra)	K	3,500 ± 10%	
R9 specific index	N/A	60 ±5	
Colour rendering index	N/A	95	
Shadow dilution	With one mask	%	74
	With two masks	%	47
	At base of tube	%	100
	With one mask, at base of tube	%	74
	With two masks, at base of tube	%	47
Radiating energy	mW.m ⁻² .lx ⁻¹	≤ 4.4	
Ambient light			
Illumination	lux	< 500	
Other specifications			
Electrical class	–	Class I	
Protection rating against a hazardous inflow of water	–	Ordinary	
Protection rating against electrical shocks	–	No parts applied	
Sterilisation and disinfection methods	–	See User's manual	
Operating mode	–	Continuous service	

Note:

- The values given with tolerances are guaranteed on the date of purchase of the product.
- The values given without tolerances have been measured by an authorised body on a production sample.

2 CLEANING, DISINFECTION AND STERILISATION

Users must contact their hospital's sanitary specialists. The recommended products and procedures must be applied. Should there be any doubt concerning the compatibility of active agents to be used, contact the local Maquet customer service department.

2.1 CLEANING AND DISINFECTING THE SURGICAL LIGHT



RECOMMENDATION

Check that the power is switched off and the light has cooled down before starting cleaning.

GENERAL INSTRUCTIONS CONCERNING CLEANING, DISINFECTION AND SAFETY

- Remove the sterilisable handles.
- Wipe the equipment with a cloth moistened with a surface cleaner. Follow the manufacturer's dilution, application time, and temperature recommendations.
- Rinse the unit with a cloth and clean water. Wipe dry.
- Wipe evenly with a cloth moistened with disinfectant. Follow the manufacturer's recommendations.
- Use a cloth to rinse with clean water in order to remove residues (in particular products containing aldehydes, quaternary ammonium or surfactants).
- with a dry cloth.
- Make sure no liquid residue is left on the device after cleaning.

RECOMMENDED PRODUCTS

Getinge USA product: TEC-QUAT 256.

Anios products: SURFA'SAFE; 0,5% HEXANIOS G + R; ANIOSYME P.L.A; SALVANIOS pH10; ANIOS DDSH.

Schülke & Mayr products: ANTIFECT PLUS.

PROHIBITED PRODUCTS



WARNING

Containing glutaraldehyde, phenol, iodine, bleach, alcohol or chloride ions must not be used. Fumigation methods are unsuitable for disinfecting the unit and must not be used.

2.2 CLEANING AND STERILISING THE HANDLES

BEFORE CLEANING

- Use a soft cloth immediately after use to wipe away soiling from the handle surface.
- Store handles in a place that keeps them moist to make further cleaning easier.
- Take care to store them in such a way that the inside does not get soiled.

CLEANING

- Immerse the handles in a detergent solution.¹
- Soak for 15 minutes to allow the solution to act, then clean by hand with a soft brush and a lint-free cloth.
- During cleaning, check regularly that the handles are fully clean and that no soiling remains on the inside or outside.
- If any soiling remains, repeat cleaning or use an ultrasonic cleaning process.
- Rinsing: Rinse thoroughly in clean water to completely eliminate the detergent solution.
- Drying: Wipe with a clean lint-free cloth.

DISINFECTION

Handles may be disinfected by machine (e.g. Getinge) and rinsed at a maximum temperature of 93°C.

Typical recommended cycles:

Stage	Temperature	Time
Pre-wash	18 - 35° C	60 sec
Wash	46 - 50° C	5 min
Neutralisation	41 - 43°C	30 sec
Wash 2	24 - 28°C	30 sec
Rinse	92 - 93°C	10 min
Dry		20 min

¹ A non-enzyme-based detergent is recommended. Enzymatic detergents may damage the handles. Never soak the handles in these detergents for prolonged periods. Rinse thoroughly.

STERILISATION

After cleaning, the handles must be steam sterilised as set out below:

Countries	Sterilisation cycle	Temperature [°C]	Time [min]	Drying [min]
USA & Canada	Prevacuum ¹	132 - 135	10	16
France	ATNC (Prion) (Prevacuum)	134	18	
Other countries	Prevacuum ¹	Comply with national regulations		

- Check that each handle is clean before continuing the process.
- Wrap the handles with sterilisation wrapper material (double wrapper or equivalent). They may also be placed in paper or plastic sterilisation bags², for easier identification and reuse.
- Place the handles on steriliser trays with the opening downwards.³
- Package with biological and/or chemical indicators for monitoring the sterilisation process, in accordance with applicable regulations.
- Run the sterilisation cycle according to the steriliser manufacturer's instructions.



RECOMMENDATION

- To ensure correct sterilisation do not allow any soiling to penetrate inside the handle.
- Handles are guaranteed for no more than 50 sterilisation cycles when the above sterilisation parameters are used.
- Dispose of sterilisable handles in the same way as other hazardous products in a hospital environment.

¹ This handle is made of a porous material.

² Possible sterilisation bag suppliers :

Medical Action Industries







SBW Medical

Baxter International

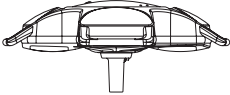
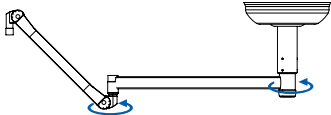
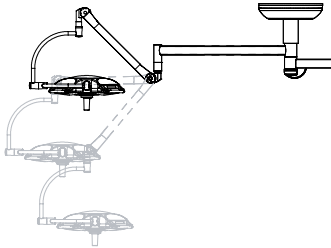
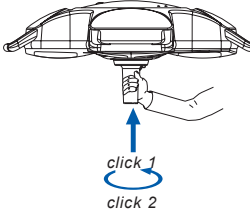
³ For air removal and faster drying.

3 GENERAL MAINTENANCE

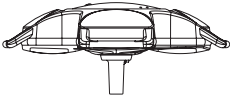
3.1 FIRST LEVEL MAINTENANCE

Daily check (operator)	
	<ul style="list-style-type: none"> ■ Check the lightheads for chipped paint, impact marks and any other damage.
	<ul style="list-style-type: none"> ■ Check the stability/drift of the main arms and the spring arms.
	<ul style="list-style-type: none"> ■ Check that the spring arm remains in position. ■ Three checkpoints: bottom, middle, top.
	<ul style="list-style-type: none"> ■ Check whether the sterilisable handle clicks and locks in place correctly; replace it if not.
	<ul style="list-style-type: none"> ■ Check whether the system switches correctly between the surgical light and the ambient light.
	<ul style="list-style-type: none"> ■ Check that the bulbs operate correctly.
	<ul style="list-style-type: none"> ■ Check whether the backup power supply turns on and the light operates correctly if a power cut were to occur (see section 3.3).
Monthly checks (only X'TEN control boxes with battery backup)	
	<ul style="list-style-type: none"> ■ Check the lightheads for chipped paint, impact marks and any other damage.
	<ul style="list-style-type: none"> ■ Check whether the backup power supply turns on and the light operates correctly if a power cut were to occur (red LED). ■ Check the capacity of the batteries (see section 3.3).

3.2 YEARLY MAINTENANCE

To keep your surgical light's original performance and reliability and in the interest of safety, annual maintenance and inspections should be performed by:

- Maquet technicians
- Maquet-accredited distributors
- Hospital technicians trained in MAQUET SAS lights.

Note: Please contact your local Maquet office for the training solution which best meets your requirements.



RECOMMENDATION

- We strongly recommend that all maintenance of surgical lights be carried out as part of a maintenance contract with Maquet.



WARNING

The operation and safety of the device may be affected by the removal of certain components during servicing operations. For example:



- When servicing the electrical power supply,
- When servicing the suspension arm and balance system.
- When servicing the optical system of lightheads equipped with filters designed to eliminate radiation not visible to the patient. Surgical lights must never be used without these filters. Contact the authorised Maquet after-sales service department for this type of inspection.



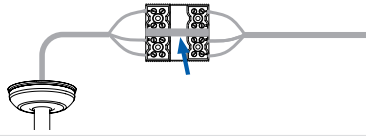
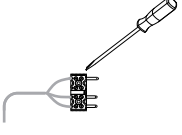
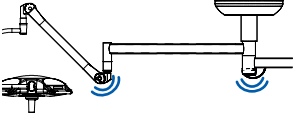
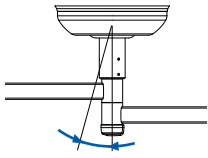

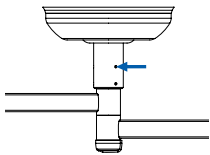
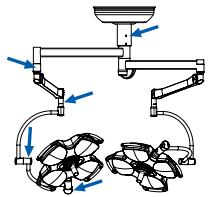
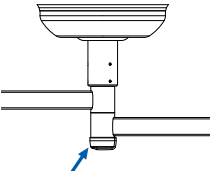
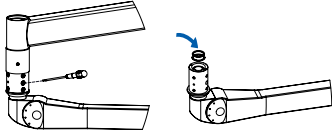
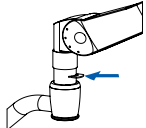
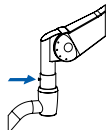
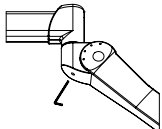
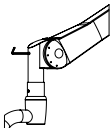
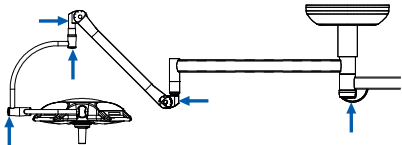
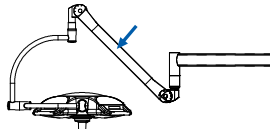
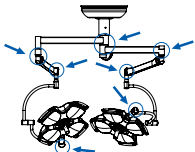
Annual checks

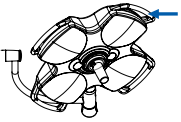
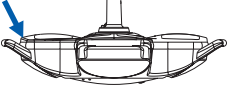
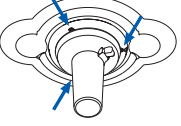
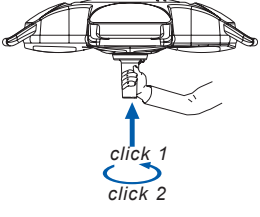
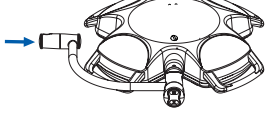
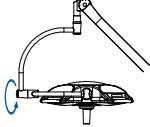
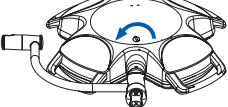
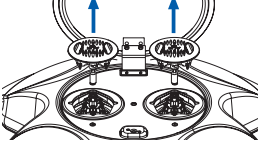
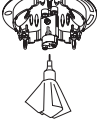

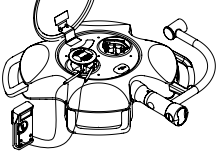
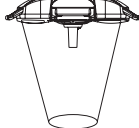
The instructions in bold are safety items

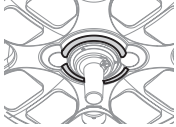
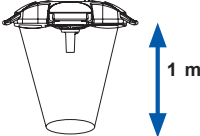

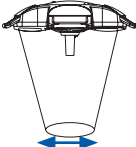
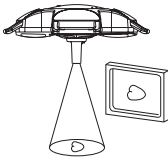
	<ul style="list-style-type: none"> ■ Check that the clamp is correctly fastened around the power supply connector in the false ceiling.
	<ul style="list-style-type: none"> ■ Check that the wires are tightly fastened to the connector.
	<ul style="list-style-type: none"> ■ Check that the suspension is firmly attached by shaking the configuration.
	<ul style="list-style-type: none"> ■ Check that the suspension tube is vertical.

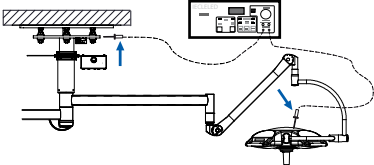
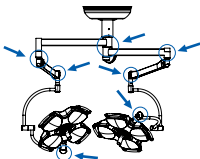
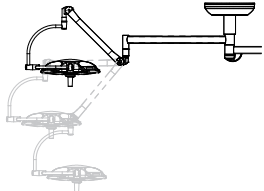
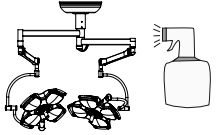
	<ul style="list-style-type: none"> ■ Every six years, as a preventive measure, replace the mounting screws holding the suspension tube to the anchor point with new pre-glued screws, and tighten to torque (refer to the appendix in the technical manual). ■ Check that the seals are correctly located.
	<ul style="list-style-type: none"> ■ Check that all visible screws are tightly fastened.
	<ul style="list-style-type: none"> ■ Check that the slotted nut is tightly fastened for suspensions with stop.
	<ul style="list-style-type: none"> ■ Check the assembly of the spring arm and the positioning of the circlips. <div style="background-color: #0056b3; color: white; padding: 5px; display: flex; align-items: center;"> <p>RECOMMENDATION</p> </div> <p style="text-align: center;">Replace the spring arm every 6 years.</p>
	<ul style="list-style-type: none"> ■ Check that the snap ring is present and in the right position (between the spring arm and the fork, and between the fork and the lighthead).
	<ul style="list-style-type: none"> ■ Check the wear of the retaining ring (remove and lubricate).
	<ul style="list-style-type: none"> ■ Check that the spring arm is balanced.
	<ul style="list-style-type: none"> ■ Adjust the top stop on the spring arm.
	<ul style="list-style-type: none"> ■ Check for any loose covers and caps.
	<ul style="list-style-type: none"> ■ Check for any loose side plastic covers. ■ Check the general appearance of side plastic covers.
	<ul style="list-style-type: none"> ■ Check the front pivot on the DF Acrobat 2000 spring arm (in case manufacturing date is between 2000 and 2006). Replace the spring arm at the slightest sign of visible cracking.

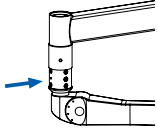
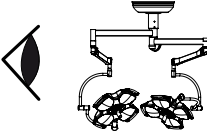
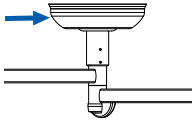
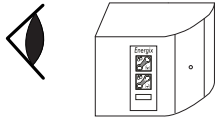
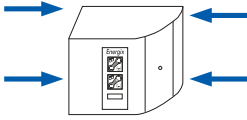
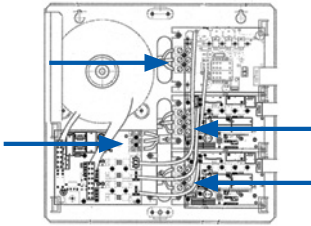
	<ul style="list-style-type: none"> ■ Check the overall condition of the side handles ■ Check that the side handles are not loose.
	<ul style="list-style-type: none"> ■ Check the condition of the lighthouse seals.
	<ul style="list-style-type: none"> ■ Check that the sterilisable handle bracket is not loose.
	<ul style="list-style-type: none"> ■ Check the locking mechanism for the sterilisable handle.
	<ul style="list-style-type: none"> ■ Remove the fork cap and make sure the slip ring is not loose.
	<ul style="list-style-type: none"> ■ Check that the stop on the fork works properly.
	<ul style="list-style-type: none"> ■ Check the cover closing mechanism.
	<ul style="list-style-type: none"> ■ Replace the two lamp brackets.
	<ul style="list-style-type: none"> ■ Replace the bulbs.
	<ul style="list-style-type: none"> ■ Check that the underside is in good condition.
	<ul style="list-style-type: none"> ■ Measure the supply voltage at the terminals of the bulb with maximum lighting (using the OPM077: 5 720 77 999): $U = 23.5 \text{ V} \pm 1 \text{ V (AC + DC)}$ or $U = 20.8 \text{ V} \pm 1 \text{ V (DC)}$
	<ul style="list-style-type: none"> ■ Check the focus and adjust the tilt of the mirrors if necessary.

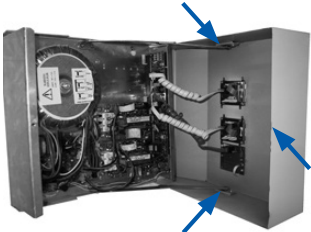
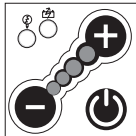
	<ul style="list-style-type: none"> ■ Check that the LED / surgical light switchover works correctly.
	<ul style="list-style-type: none"> ■ Check that the LED ring works correctly: four intensity levels.
	<ul style="list-style-type: none"> ■ Check standard illumination at 1 metre: Serial no. < 20,000: 110,000 lux ± 15 % Serial no. > 20,000: 130,000 lux minimum
	<ul style="list-style-type: none"> ■ Check maximum illumination of the ring of LEDs: Serial no. < 20,000: 150 lux ± 10 % Serial no. > 20,000: 210 lux ± 10 %
	<ul style="list-style-type: none"> ■ Check the light patch diameter: Serial no. < 20,000: 25 cm ≤ diameter ≤ 30 cm Serial no. > 20,000: 24 cm ≤ diameter ≤ 30 cm
	<ul style="list-style-type: none"> ■ Check that the camera operates correctly (CFF or VZ): stable and clean image.
	<ul style="list-style-type: none"> ■ Check that all the standards labels are in place: exclamation mark, hot, bulb holder.
	<ul style="list-style-type: none"> ■ Measure the earth bonding on all visible metal conductor parts with an earth bonding tester: $R \leq 0.1 \text{ Ohm}$.
	<ul style="list-style-type: none"> ■ Ensure there are no points of friction when the arm and the lighthouse rotate.
	<ul style="list-style-type: none"> ■ Check the movement of the equipment and how stable the lighthouse is in each position. ■ Adjust the brakes if necessary.
	<ul style="list-style-type: none"> ■ Clean the entire configuration with ECL NET or soap water. ■ Do not use alcohol to clean the underside.

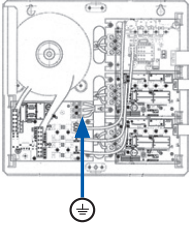
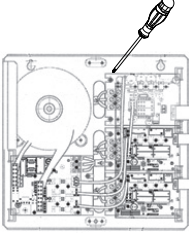
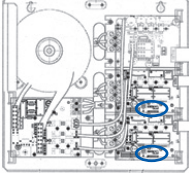
	<ul style="list-style-type: none"> ■ Check that there is no corrosion, in particular on the main arm, beneath the safety clamp.
	<ul style="list-style-type: none"> ■ Check that there is no chipped paint.
	<ul style="list-style-type: none"> ■ Check for any loose ceiling covers
	<ul style="list-style-type: none"> ■ Check the general appearance of the Energix cover (no corrosion, no chipped paint).
	<ul style="list-style-type: none"> ■ Check that the Energix control box is well fastened to the wall.
	<ul style="list-style-type: none"> ■ Open the ENERGIX control box and check that the connectors are tightly fastened.
<div style="border: 1px solid black; padding: 5px; width: fit-content;"> <p>ENERGIX SOFTWARE VERSION Vx.xx</p> </div>	<ul style="list-style-type: none"> ■ In START UP menu, check the software version of the Microcontroller Board. If the software version is before 5.40 (2.05;2.06 for example), inform the customer that this version is obsolete. See NIT 188 for more informations.
	<ul style="list-style-type: none"> ■ Turn the lighthouse on and simulate a power supply failure. ■ Check that the switch to batteries (see next page) and to the establishment's emergency system is working. ■ Illumination should remain at > 40,000 lux for at least 1 hour.
	<ul style="list-style-type: none"> ■ Check that the hinges and the cover are tightly fastened.
	<ul style="list-style-type: none"> ■ Check the condition of the control keypad. ■ Check the eight illumination levels

	<ul style="list-style-type: none"> ■ Check the earth bonding for the Energix control box.
	<ul style="list-style-type: none"> ■ Check that none of the circuit boards in the Energix control box are loose.
	<ul style="list-style-type: none"> ■ Check that the settings of the Energix control box match the type of configuration.
	<ul style="list-style-type: none"> ■ Check the connection of the cables to the batteries.



WARNING

Take care when handling the circuit boards: these boards are supplied in an electrostatic envelope and must be handled with great care. Certain components on the boards may be destroyed by static electricity (ESD, electrostatic discharge). An anti-static wrist strap (OPM 060) must be worn to eliminate this risk.

3.3 BATTERY CAPACITY TEST



WARNING

In the event of a power cut, only lightheads connected to a backup power supply will remain on.

- The power supplies may be optionally equipped for use with your operating room's 24 V backup power supply.
- If the mains supply is restored after being cut, the light turns on in surgical light mode.

	<p>Red LED</p>	<p>Backup power supply on (WPS XX1 only)</p>
--	----------------	--

BATTERY BACKUP TEST (DAILY CHECK)

	<ul style="list-style-type: none"> ■ Press and hold the On/Off button for three seconds. 	
	<ul style="list-style-type: none"> ■ The backup batteries take over. ■ The LED turns from green to red. ■ The lighthead automatically switches back to the mains supply three seconds later. 	

BATTERY CAPACITY TEST (MONTHLY CHECK)

	<ul style="list-style-type: none"> ■ Turn on the lighthead. 	
	<ul style="list-style-type: none"> ■ Press and hold the + and - buttons for two seconds. 	
	<ul style="list-style-type: none"> ■ The backup batteries take over. ■ Allow the batteries to discharge (one hour per lighthead). 	
<p>BATTERY GOOD</p>	<ul style="list-style-type: none"> ■ Battery charge sufficient. 	
<p>BATTERY BAD</p>	<ul style="list-style-type: none"> ■ Replace the batteries. 	
	<ul style="list-style-type: none"> ■ Press the On/Off button to interrupt the test or to switch back to the mains supply. 	

4 MAINTENANCE PROCEDURES

4.1 REMOVING THE HANDLE

Tool: Cross-head screwdriver

- Remove the sterilisable handle.
- Loosen the handle's captive screws.
- Remove the handle.
- For reassembly, follow the procedure in the reverse order.

4.2 REMOVING THE UNDERSIDE

Tool: 2.5 mm Allen key

- The underside can only be removed once the handle has been taken off.
- The underside is attached to the lighthouse by 4 screws. These screws are hidden by the white seal. To extract the underside, remove the four screws.



WARNING

- X'Ten (Serial No. <20000): The underside is made up of a single part.
- X'Ten (Serial No. >20000): The underside is made up of one internal part and one external part. When reassembling, take care when attaching the internal face. The two openings must line up with the two lamp brackets.
- X'Ten (May 2009): The underside is made up of a single part.

4.3 REMOVING GRIP HANDLES

Tool: 3 mm Allen wrench, cross-head screwdriver, T-20 Torx wrench

- The handles can only be removed once the underside has been taken off.
- Remove the cover, unscrewing the two M5 socket head cap screws.
- Remove the two lamp brackets.
- Unclip the tube clamps.
- Remove the five ULF M5 screws.
- Remove the shell of the optical mounting plate then, unscrew the two PT K screws.
- Reinstall the grip handles and proceed in the reverse order.

4.4 REMOVING RIGHT AND LEFT CONDENSERS

Tool: 2.5 mm Allen wrench and 9 mm box spanner

- The right and left condensers can only be removed once the underside has been taken off.
- Open the cover.
- Remove the two lamp brackets.
- Remove the three M3 socket head cap screws and the female plug.
- Withdraw the condenser.
- Reinstall the condenser and follow the procedure in the reverse order.
- Let the mirror S/A tilt towards you.
- Carefully separate the mirror bracket to free up the shafts of the mirror S/A.
- Reinstall the mirror S/A and follow the procedure in the reverse order.

4.5 REMOVING THE CENTRAL FILTER

Tool: Cross-head screwdriver

- The central filter can only be removed once the left or the right condenser has been taken off.
- Unscrew the four screws (11).
- Remove the two clamps (3).
- Remove the faulty filter and replace it with a new one.
- Reinstall the two clamps (3).
- Screw the four bolts back in again (11).
- Reinstall the condenser and follow the procedure in the reverse order.



WARNING

- Do not remove the condenser lenses. After they are put back, the lenses would not be in their optimal position. The illumination of the lighthouse might be below minimum illumination.

4.6 REMOVING THE FIXED MIRROR S/A

Tool: 5.5 mm spanner

- The fixed mirror S/A can only be removed once the underside has been taken off
- Turn the lighthouse over.
- Remove the cover, unscrewing the two M5 socket head cap screws.
- Remove the two lamp brackets.
- Remove the five ULF M5 screws.
- Unclip the tube clamps.
- Remove the shell of the optical mounting plate.
- Turn the lighthouse over again.
- Remove the Th M3 screw, taking care not to let the support mirror spacer fall.
- Carefully separate the mirror bracket to release the shafts of the mirror S/A.
- Reinstall the mirror S/A by following the procedure in the reverse order.

4.7 REMOVING THE MOBILE MIRROR S/A

Tool: OPM handle spanner

- The mobile mirror S/A can only be removed once the underside has been taken off.
- Turn the lighthouse over.
- Remove the cover, unscrewing the two M5 socket head cap screws.
- Remove the two lamp brackets.
- Remove the five ULF M5 screws.
- Unclip the tube clamps.
- Remove the shell of the optical mounting plate.
- Turn the lighthouse over again.
- Force out the 3.2 mm circlips.
- Extract the mirror S/A from the bush, by lighting moving the lever.

4.8 REMOVING THE CONTROL ROD

Tool: T-10 Torx wrench, 2.5 mm Allen key

- The control rod can only be removed once the mobile mirror S/A has been taken off.
- Remove the screw (14).
- Remove the two screws (27).
- Reinstall the grip handle (28) and follow the procedure in the reverse order.

4.9 REMOVING THE CAM

Tool: 3 mm Allen key.

- The cam can only be removed once the underside has been taken off.
- Remove the retaining screw of the cam, taking care not to let the Hu M4 nut and the spacer fall.
- Turn the cam 5° to extract the cam mounting plate.
- To make reassembly of the cams easier, at the same time keep the control rods in a retracted position.

4.10 REMOVING THE WIRING LOOM

Tool: 10 mm spanner, 9 mm spanner

- The wiring loom can only be removed once the left and the right condensers have been taken off.
- Remove the two retaining screws from their lugs.
- Change the loom.
- Reinstall the items by following the procedure in the reverse order.

5 MAINTENANCE KITS

Description	Quantity	Part number
Rotating non-video 3-track contact repair kit		367208555
male contact	1	699899694
female contact	1	699889697
5-track video slip rings		567801135
5-track male contact	1	
5-track female contact + cables	1	
10-pin connector	1	
Endo switch S/A		367802998
Endo switch	1	567801161
Retaining screw	1	600580408
Lexan S/A		367803998
Lexan end cap dimmer	1	567501132
Lexan endo switch	1	567801101
LED S/A		367804998
Circuit LEDs	1	567801023
PTK screws	4	600990081
Cover S/A		367810998
Star washer	2	602420595
M5x10 Cocket head cap scre	2	600530510
Cover	1	567202392
Cast-moulded Button	1	567202276
Cover seal	1	567202405
Underside S/A (serial numbers < 20,000)		367811998
Underside	1	567801021
FHc M4x10 screws	4	600410410
Right condenser S/A (serial numbers < 20,000)		367821998
S/A right condenser	1	567801982
M3x20 socket head cap screw	3	600530320
D3 Star washer	3	602390306
Female plug	1	567801015
Left condenser S/A (serial numbers < 20,000)		367822998
S/A left condenser	1	567801994
M3x20 socket head cap screw	3	600530320
D3 Star washer	3	602390306
Female plug	1	567801015
Underside S/A (serial numbers > 20,000)		367834998
Underside	1	567801164
Underside	1	567801165
FHc M4x10 screws	4	600410410
Right condenser S/A (serial numbers > 20,000)		367835998
S/A right condenser	1	567801973
M3x20 socket head cap screw	3	600530320
D3 Star washer	3	602390306
Female plug	1	567801015

Left condenser S/A (serial numbers > 20,000)		367836998
Left condenser S/A	1	567801975
M3x20 socket head cap screw	3	600530320
D3 Star washer	3	602390306
Female plug	1	567801015
Underside S/A (May 2009)		367837555
Underside	1	567801180
FHc M4x10 screws	4	600410410
Shell S/A		367812998
Shell S/A	1	567801984
ULF M5x8 screws	5	600990076
Wrench		696763273
Grip handle S/A		367813998
Grip handle	1	567801027
Boss	2	567801048
PTK 50x20 screws	2	600990089
Support bracket	1	567801099
Grip handle S/A (May 2009/white)		367839555
Grip handle	1	567801202
Boss	2	567801048
PTK 50x20 screws	2	600990089
Support bracket	1	567801099
4 grip handle S/As (Grey)	1	367840555
Grey grip handle	4	567801202
Boss	8	597801048
PTK 50x20 screws	8	600990089
Support bracket	4	567801055
Seals kit		367816555
Underside seal	1	567801028
Fork seal	1	567801029
Seals kit (May 2009)		367838555
Underside seal (grey)	1	567801203
Fork seal	1	567801029
Control rod S/A		367814998
Control rod S/A	1	567801998
PT K30x8 screws	1	600990081
M3x16 socket head cap screw	2	600530316
Hu M3 nut	2	601320324
S/A Tilt handle	1	367840998
Set of brake screws		367815555
Brake screw	5	657700002
Set of lighthouse snap rings		367817555
Snap ring	5	567801052

Female plug kit		367818555
Female plug	4	567801015
Insulating washer	4	567801081
Insulating bush	4	567801014
D6 star washer	4	602420611
Hm M6 nut	4	601410603
Set of tube plugs		367819555
Tube plug	10	567202415
S/A fixed mirror		367820998
Fixed mirror S/A	1	567801974
THM3*10 screw	1	600260310
M3 washer	1	602120832
Spacer	1	567501175
S/A Mobile mirror	1	367823998
Mobile mirror S/A	1	567801972
Mobile mirror S/A 3.2 mm circlips	1	639800341
Central filter	1	567502002
Protective bezel central video shaft video S/A	1	367800001
Suspension Bushing repair S/A MS - X'Ten HLX 3000	1	367820555
M12x100 brake (L: 13 mm)	2	567802032
End cap for Acrob. 300 spring arm with stop	1	567802979
M6x8 FHC screw, stainless steel	4	600410608
Needle bush HK4020	2	623600028
Standard suspension Bushing repair S/A MS	1	367821555
M12x100 brake (L: 17 mm)	2	567802029
End cap for spring arm	1	567802981
M6x8 FHC screw, stainless steel	4	600410608
G05 D4X10 Steel 250 Zinc-plated Pin	2	603050410
Needle bush HK 32x39x24	2	56680039
Suspension Bushing repair S/A FS	1	367822555
M12x100 brake (L: 17 mm)	2	567802029
End cap for spring arm with stop	1	567802980
End cap for spring arm with stop	1	567802013
M6x8 FHC screw, stainless steel	4	600410608
Needle bush HK 32X39X24	2	56680039
X'Ten Kit - Primalix optics demonstration	1	367823555
Fixed cold mirror	1	567501306
Connector 4000 sector	1	567202083
Power	1	567801039
Video connector suspension S/A - X'Ten HLX 3000	1	367824555
Contact mounting plate	1	567802006
Brushes D50 5 tracks + connector	1	567802021
M4x6 Socket head cap screw, stainless steel	2	600530406
TH ECO-FIX M5X10 zinc-plated steel screw	1	600990036
9-15 kg X'Ten balance arm cover kit	1	367825555

X'Ten kit SF spring arm fittings	1	367826555
Ring for SF spring arm	1	567801130
M6x10 FHC screw, stainless steel	3	600410610
AZV M6 Star washer	3	602420017
Stop of M5X10 screw	1	567801144
M4x8 Socket head cap screw, stainless steel	2	600530408
M5X20 Steel Nickel-plated CHC screw	3	600520520
M5X16 FHC Steel Nickel-plated screw	3	600400516
SF spring arm foil - SAT X'Ten HLX 3000	1	367827555
SF spring arm cap kit - SAT X'Ten HLX 3000	1	367828555
SF spring arm brake kit - SAT X'Ten HLX 3000	1	368306900
SF spring arm circlips - SAT X'Ten HLX 3000	1	639411312

6 SPARE PARTS AND CONSUMABLES

Description	Quantity	Part number
24 V/100 W halogen bulb	1	186762
S/E X'TEN Lamp bracket TM	1	367501950
Set of five sterilisable handles for lighthead without camera	1	367203976
Set of five sterilisable handles for lighthead with camera (PSX004)	1	367203975
1 litre can of anti-static ECL NET product cleaner	1	606201001
500 ml spray for ECL NET	1	606201002
150 ml white acryl RAL 9016 aerosol spray	1	658530007
Special grease for electrical contact	1	659000004

7 MAINTENANCE TOOLS (OPM)

Description	Quantity	Part number
OPM 039 Light meter	1	572034999
OPM 059 Multimeter M 54 RMS	1	572059999
OPM 077 Lamp voltage data sheets	1	572077999
OPM Handles of X'Ten TM assembly	1	572078999

8 DIAGRAMS AND PARTS LISTS

PART LIST 1
5 680 51 999

SUSPENSION ANCHOR POINT S/A

No.	Part number	Description	Qty
	5 138 95 999	ECL0015 anchor plate	
1	567201338	Universal plate	1
14	5 672 60 998	ECL2001 clamp	1
2	6 022 90 009	Tapered washer 16-32-3.4	6
3	6 022 90 011	High-strength washer, 17-40.6	6
4	6 023 13 016	Z16 washer	6
5	6 013 70 013	Hu M16 nuts, 10.9 grade	14
6	5 672 01 310	Upper ceiling attachment plate	1
7	5 680 09 043 to 5 680 09 054	Suspension tube (1065 to 2165) Refer to the installation recommendations for information on clearances.	1
8	5 680 37 999	Flat cover - 2 pieces (ECL 1011)	1
9	5 680 38 999	Flat cover - 2 pieces (ECL 1012)	1
10	5 672 60 999	Curved cover - 1 piece (ECL 1013)	1
11	5 672 60 997	Curved cover - 1 piece (ECL 1013)	1
12	5 672 01 327	Tube seal diam.130 mm	1
13	5 680 09 016	Seal for ceiling-mounted surgical light cover	1

DIAGRAM 1

SA SUSPENSION ANCHOR POINT

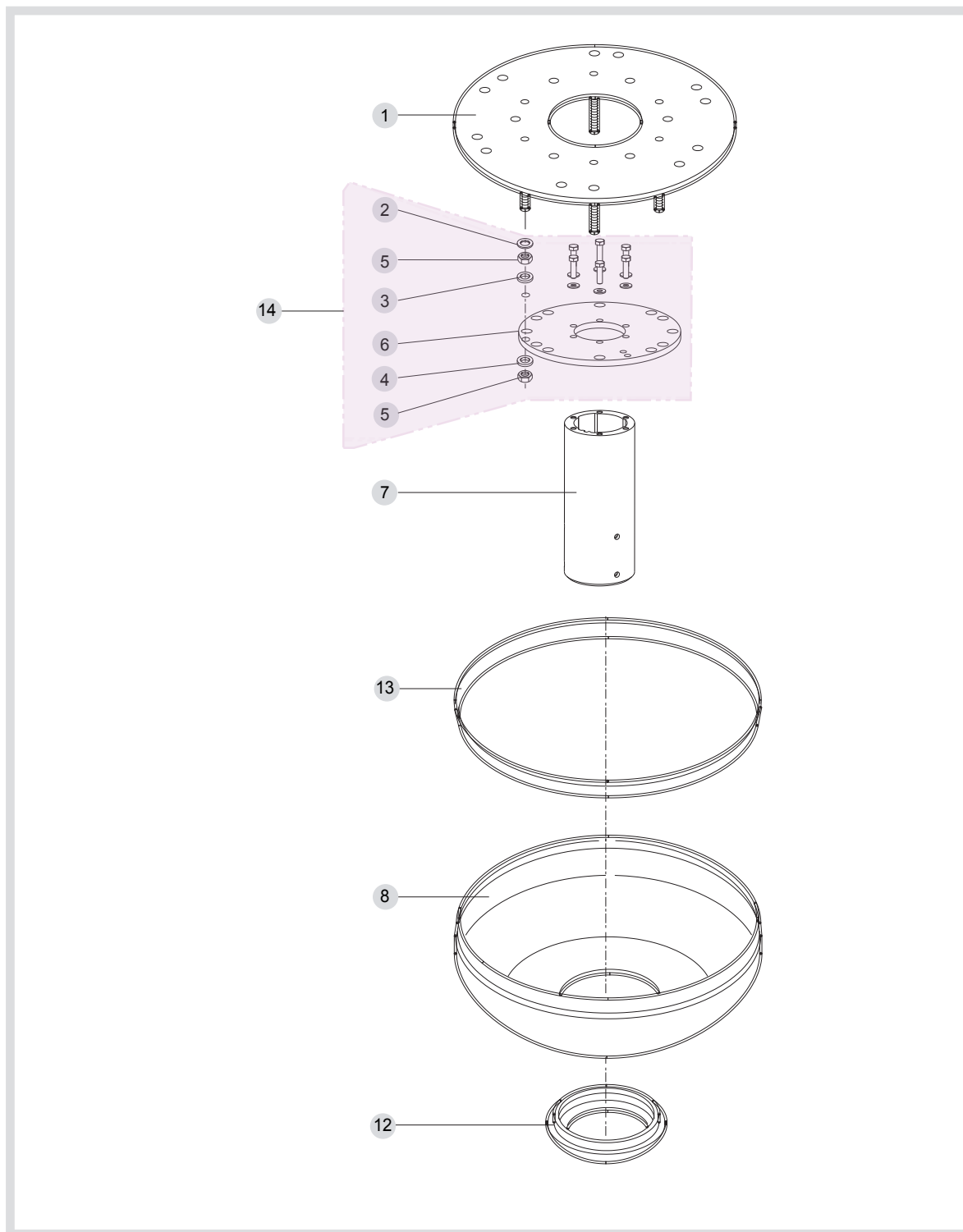

PART LIST 2

SA SUSPENSION FOR CEILING-MOUNTED SURGICAL LIGHT

No.	Part number	Description	Qty
1	6 007 40 612	Pre-glued M6x12 CHC low profile head screw	6
2	5 678 02 004	Three-arm shaft	1
3	5 678 02 024	3-track 50 mm Slip ring Dia. 50 3 tracks	1
4	5 678 02 020	BNC 50 mm Slip ring Dia. 50 5-track BNC	1
5	6 030 70 320	Pin	2
6	6 029 95 007	Spring lock washer	2
7	6 394 04 502	Circlip	4
8	6 100 61 805	Ball bearing	3
	3 978 01 555	Stop kit	1
9	6 015 60 409	Slotted nut auto-brake	1
11	5 678 02 005	Bottom stop	1
12	6 005 10 814	Mx14 Socket head cap screw	3
13	6 026 00 413	Grower washer	3
10	5 678 02 006	Video bumper	1
	3 978 02 555	Brake-screw kit (x5)	1
14	5 678 02 028	M12x100 brake	6
15	6 520 00 186	GPN cap	3
	3 978 04 555	3-track brushes + connector	1
16	5 678 02 022	3-track 50 mm Brush + connector	1
17	6 009 90 036	M4x10 TH eco-fix screw	2
18	5 678 02 008	Contact mounting plate	2
19	6 005 30 410	M4x10 Socket head cap screw	4
20	5 678 02 015	Half sliding ring	1
	3 978 03 555	Sliding ring kit	1
21	6 025 70 408	Washer	3
22	6 003 30 410	M4x10 TFB screw	3
31	5 678 02 014	Sliding ring	2
23	5 678 02 007	Cover	3
	3 678 24 555	3-track video brushes + connector	1
17	6 009 90 036	M4x10 TH eco-fix screw	2
18	5 678 02 008	Contact mounting plate	2
24	5 678 02 021	5-track 50 mm Brush + connector	1
	3 678 21 555	End cap for spring arm	1
25	5 678 02 012	End cap for spring arm	2
26	5 668 00 39	Needle bush	6
27	6 030 50 410	Pin	4
28	5 678 02 029	M12x100 brake	6
29	6 004 10 608	M6x8 FHC screw	12
	3 678 22 555	Suspension Bushing repair S/A FS (10)	1
26	5 668 00 39	Needle bush	6
28	5 678 02 029	M12x100 brake	6
29	6 004 10 608	M6x8 FHC screw	12
30	5 678 02 013	End cap for spring arm with stop	1
32	5 679 14 999	Hanau tube fastening retrofit kit	1

DIAGRAM 2

SA SUSPENSION FOR CEILING-MOUNTED SURGICAL LIGHT

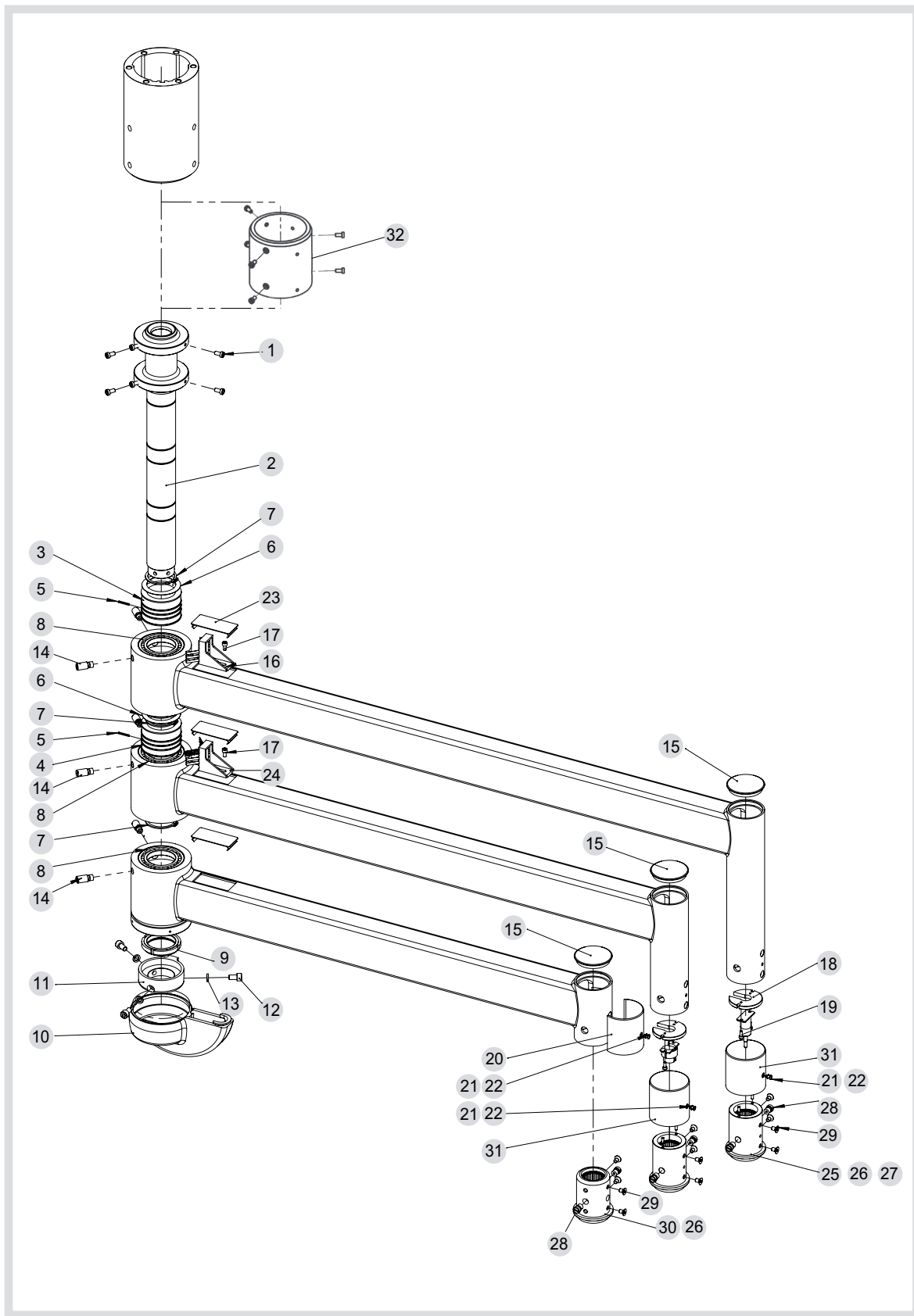

PART LIST 3

ACROBAT 2000 DF SPRING ARM

5 679 10 901

5 678 01 115

5 679 10 910

5 679 10 972

5 679 10 973

5 679 10 974

No.	Part number	Description	Qty
	3 678 25 555	DF spring arm side covers	
1		DF right cover	1
2		DF left cover	1
3		Lighthouse left cover	1
4		Lighthouse right cover	1
5		Adjustment screw cap	1
6		Suspension left cover	1
7		Suspension right cover	1
8		Flanged cover shaft	2
9		M3x16 screw	
10	3 678 32 555	Snap ring	1
	3 678 35 555	Retaining ring kit BR AC 2000 DF	
11		Retaining ring	1
12		M3x8 screw	1
13		Washer, dia. 32 mm, 3x39 mm, thickness 0.5 mm	1
14	6 394 11 312	Elastic ring, dia. 32 mm, thickness 1.5 mm	1
	560 53 311	Metal half-rings BR AC 2000 DF	
15		Metal half-ring 1	2
16		Metal half-ring 2	1
17		Metal half-ring 3	1

DIAGRAM 3

ACROBAT 2000 DF SPRING ARM

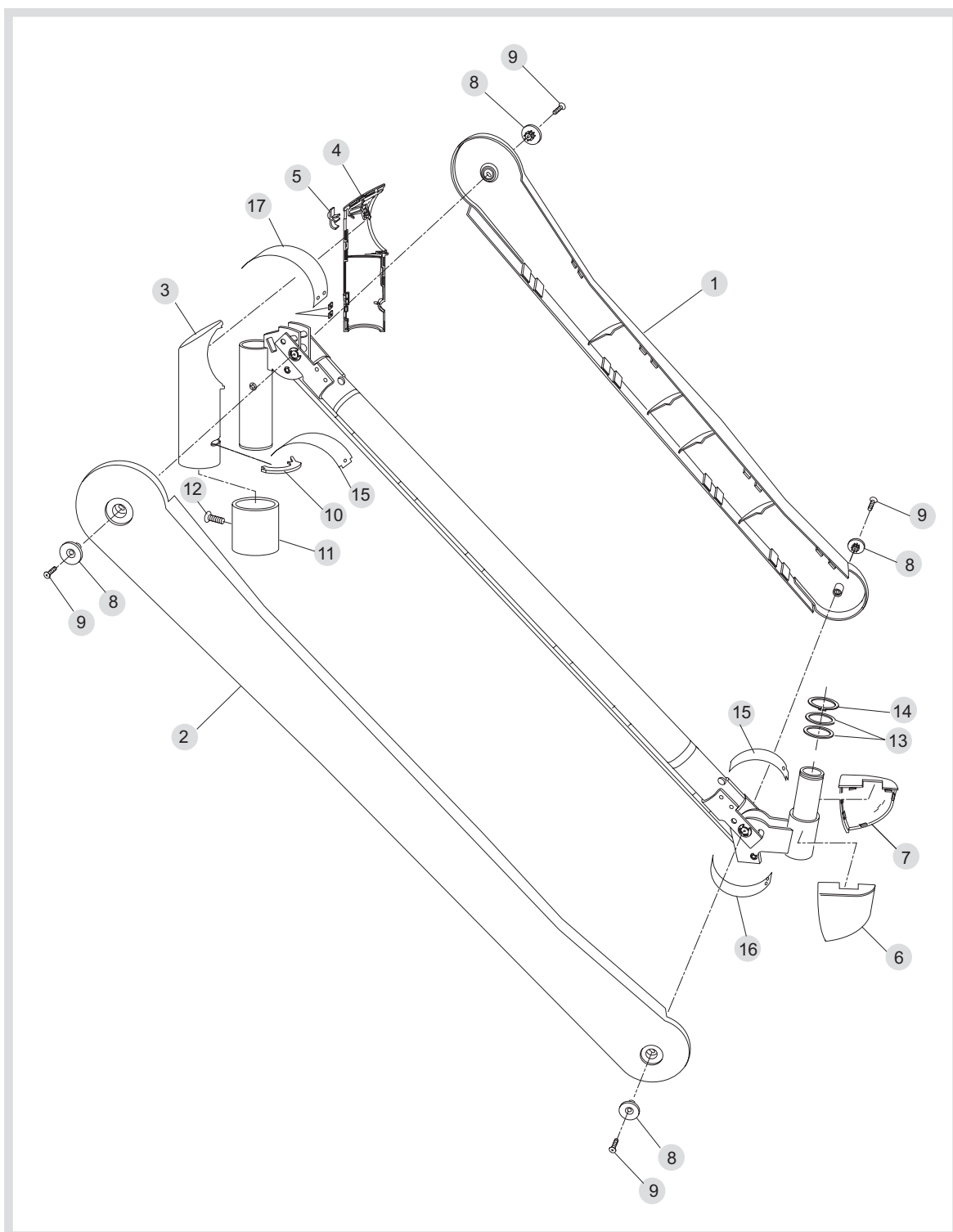

PART LIST 4

ACROBAT 2000 SF SPRING ARM

No.	Part number	Description	Qty
	3 678 28 555	Side cover S/A for SF spring-loaded arm	
1		SF right cover	1
2		SF left cover	1
3		Lighthouse left cover	1
4		Lighthouse right cover	1
5		Washer, dia. 32 mm, 3x3 mm, thickness 0.5 mm	1
6	6 394 11 312	Elastic ring, dia. 32 mm, thickness 1.5 mm	1
7	3 683 06 900	SF spring arm brake screw	1
	3 678 27 555	Metal half-rings for SF arm	
8		Flanged cover washer	2
9		M3x16 screw	2
10		Metal half-ring 1	1
11		Metal half-ring 2	1
		Adjustment tools (not shown)	
	3 675 22 555	AC 2000 SF Sleeve + brake + fixing	
13		Fixing screws	2
7		Brake screws	1
12		SF sleeve	1

DIAGRAM 4

ACROBAT 2000 SF SPRING ARM

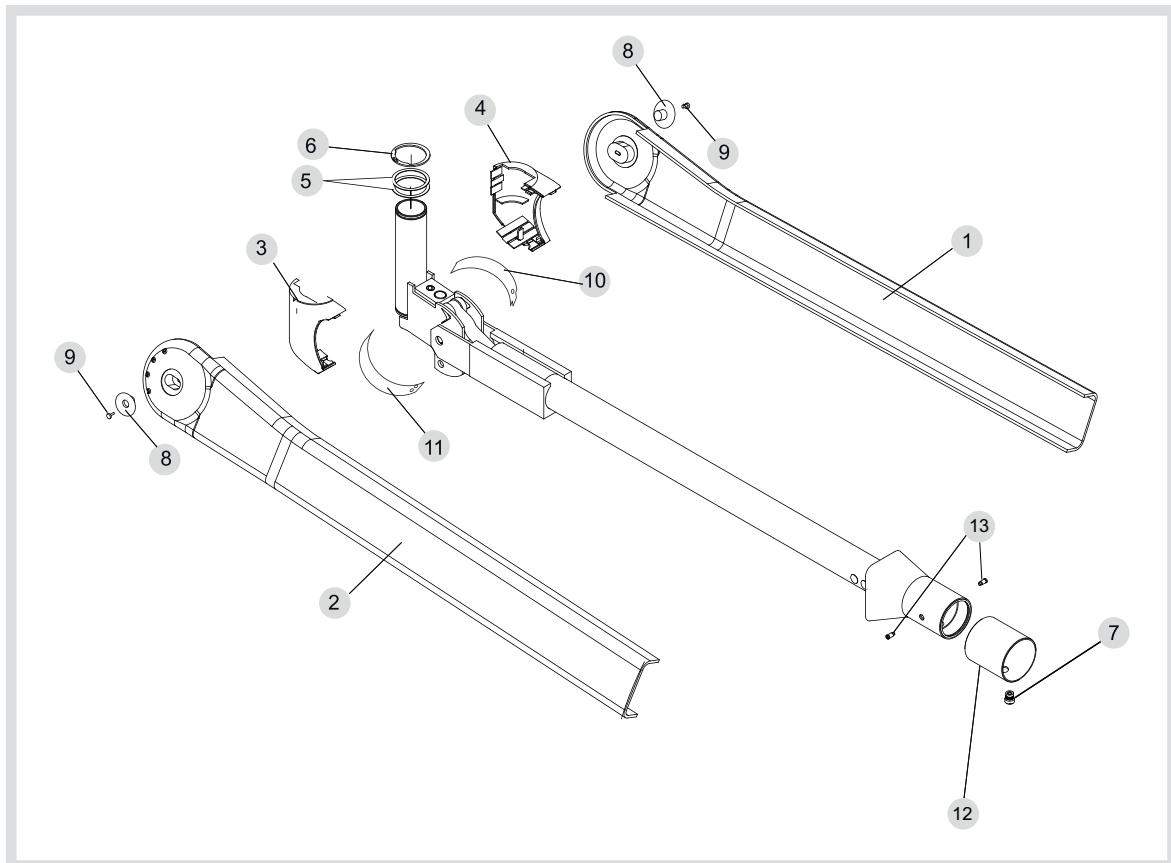

PART LIST 5

SINGLE FORK

No.	Part number	Description	Qty
1	567801130	Ring for SF spring arm	1
2	602420017	Tapered D6 star washer	3
3	600410610	M6x10 FHc screw	3
4	600530510	M5x10 Socket head cap screw	1
5	600520520	M5x20 Socket head cap screw	3
6	567801131	Shaft for SF spring arm	1
7	567801139	Video beam option for SF lighthead	1
8	567801138	Beam for SF lighthead	1
9	600530408	M4x8 Socket head cap screw	2
10	567801061	Fork	1
	3 678 19 555	Set of covers and caps (x10)	1
11	5 672 02 415	Tube plug	1
12	6 004 00 516	M5x16 FHc screw	3
13	5 678 01 081	Joint shaft	1
	3 678 02 998	S/A endo switch	1
14	5 678 01 161	End switch option	1
18	6 005 80 408	Hc flat-end M4x8 stainless steel screw	1
	3 678 03 998	Lexan S/A	1
15	5 675 01 132	Lexan end cap dimmer	1
17	5 678 01 101	Lexan option for endo switch	1
16	5 678 01 064	Cover	1
19	3 678 39 998	XTen standard single kit	1

DIAGRAM 5

SINGLE FORK

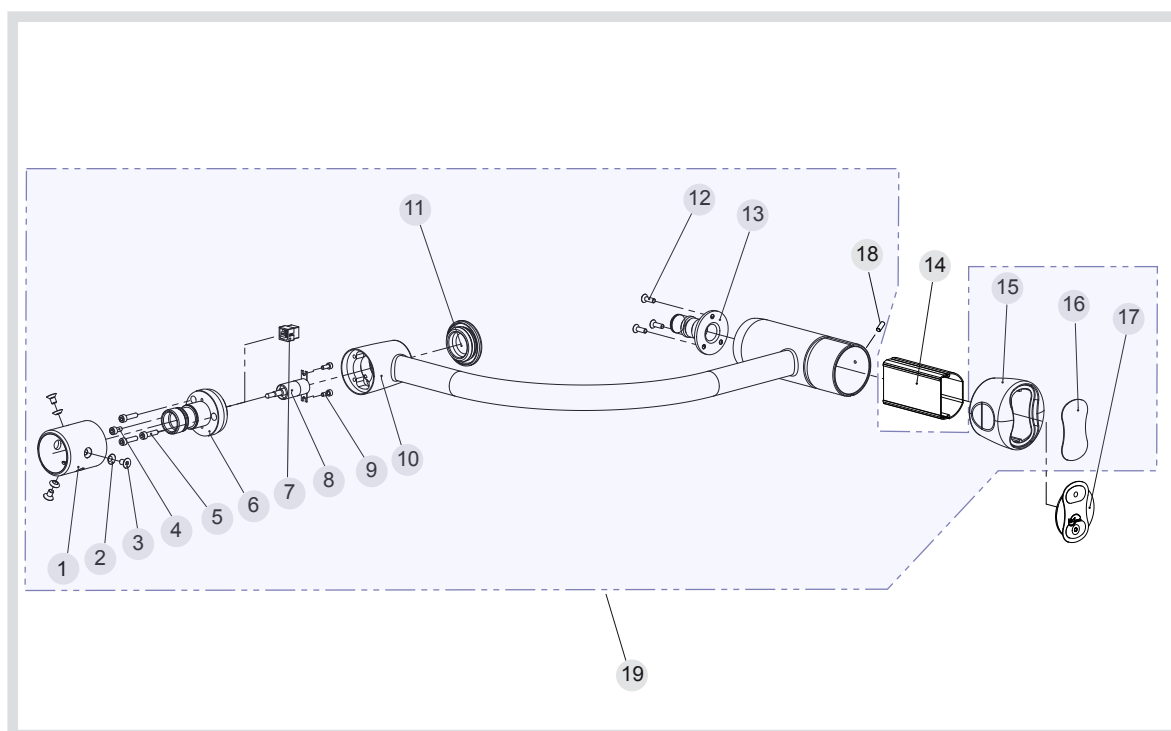

PART LIST 6

DOUBLE FORK (STANDARD OR VIDEO)

No.	Part number	Description	Qty
1	600520520	M5x20 Socket head cap screw	3
2	567801079	Joint sleeve	1
3	567801135	Video beam option	1
4	567801136	Beam for fork	1
5	602320842	Z4 washer	2
6	567801102	Spring	2
7	600530408	M4x8 Socket head cap screw	2
8	600510430	M4x30 Socket head cap screw	2
9	567801062	Fork on suspension side	1
	367819555	Set of covers and caps (x10)	1
10	567202415	Tube plug	3
11	567801061	Fork on lighthouse side	1
12	567801081	Joint shaft	2
13	600400516	M5x16 FHc screw	6
14	600530510	M5x10 Socket head cap screw	2
15	567801082	25 mm washer	1
16	623622512	Bush HK 2512	1
17	657700002	Brake	1
18	623622005	Bush HK 2212	1
19	567801083	22 mm washer	1
20	653200018	Block of 22 mm thickness	2
21	633401022	Shaft circlips, dia. 22 mm	1
	367802998	S/A endo switch	1
22	567801161	End switch option	1
26	600580408	Hc flat-end M4x8 stainless steel screw	
	367803998	Lexan S/A	1
23	567501132	Lexan end cap dimmer	1
25	567801101	Lexan option for Endo switch	1
24	567801064	Cover	1
27	367837998	XTen video double fork kit	1
28	367838998	XTen standard double fork kit	1

DIAGRAM 6

DOUBLE FORK (STANDARD OR VIDEO)

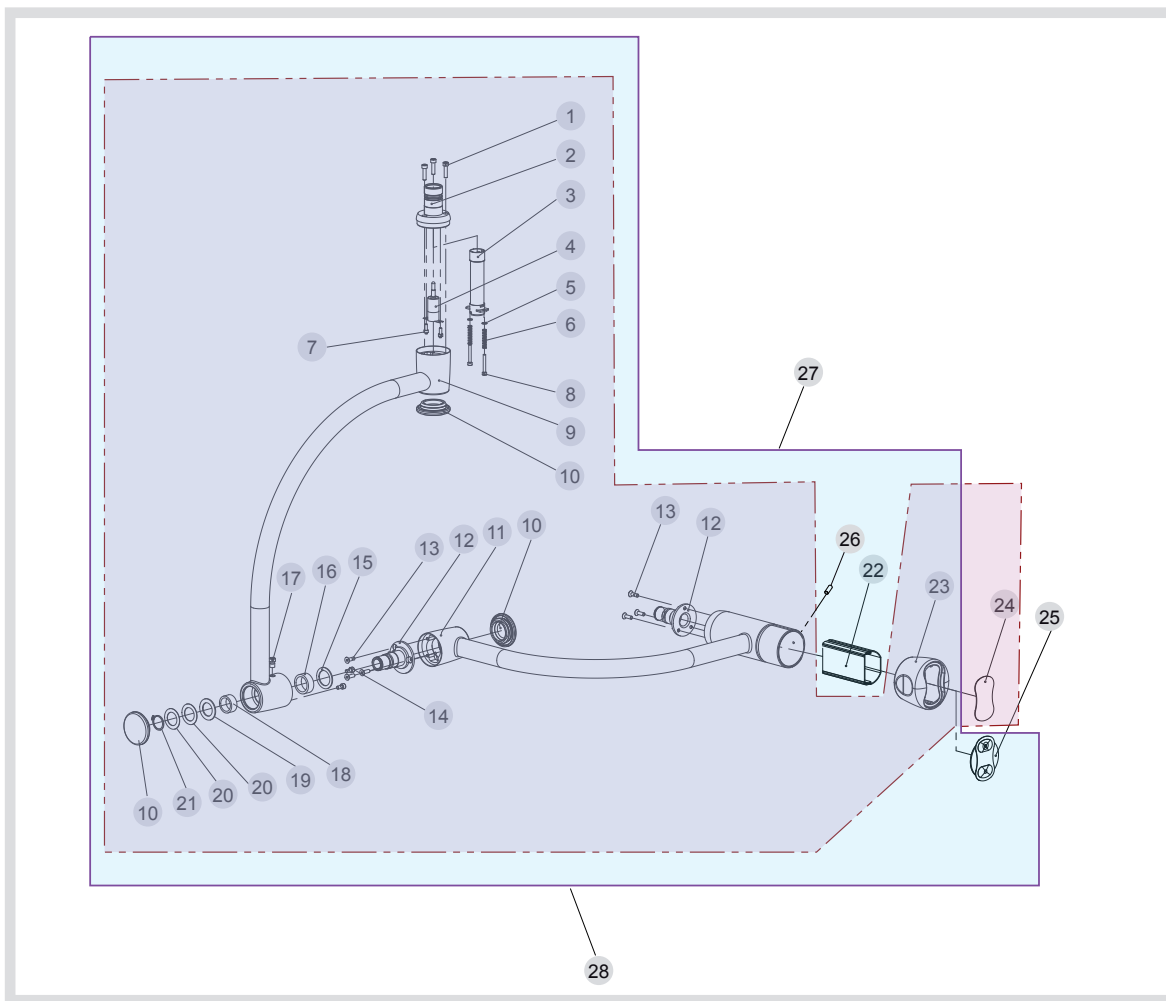

PART LIST 7

XTEN LIGHTHEAD

No.	Part number	Description	Qty
1	567801992	S/A Cover	1
2	602420595	D5 Star washer	2
3	600530510	M5x10 Socket head cap screw	2
4	567801993	SE Bulb holder	2
5	600990076	ULF M5x8 screws	5
6	567801984	S/A Shell	1
7	567801974	Fixed Mirror S/A	4
8	567801972	Mobile Mirror S/A	4
9	600430312	TH M3X12 screw	4
10	602120832	M3 washer	4
11	567501175	Spacer mirror bracket	4
12	600330410	M4x10 TFB screw	1
13	657700002	Brake	1
14	567801087	Viewing washer	1
15	567801060	Retaining ring	1
16	567801973	S/A right condenser	1
17	567801023	LED circuit option	1
18	600990081	PT K 30x8 WN5452 screw	4
19	567801975	S/A left condenser	1
20	567801052	Snap ring	1
21	600530320	M3x20 socket head cap screw	6
22	602390306	D3 Star washer	6
23	567801015	Female plug	2
24	567801997	S/A lighthouse wing	1
25	696763213	Skiffy wrench	4
26	639800341	Truarc 3.2 mm ring	4
27	600620305	Hc M3x5 stainless steel screw with sharp end	1

DIAGRAM 7

XTEN LIGHTHEAD

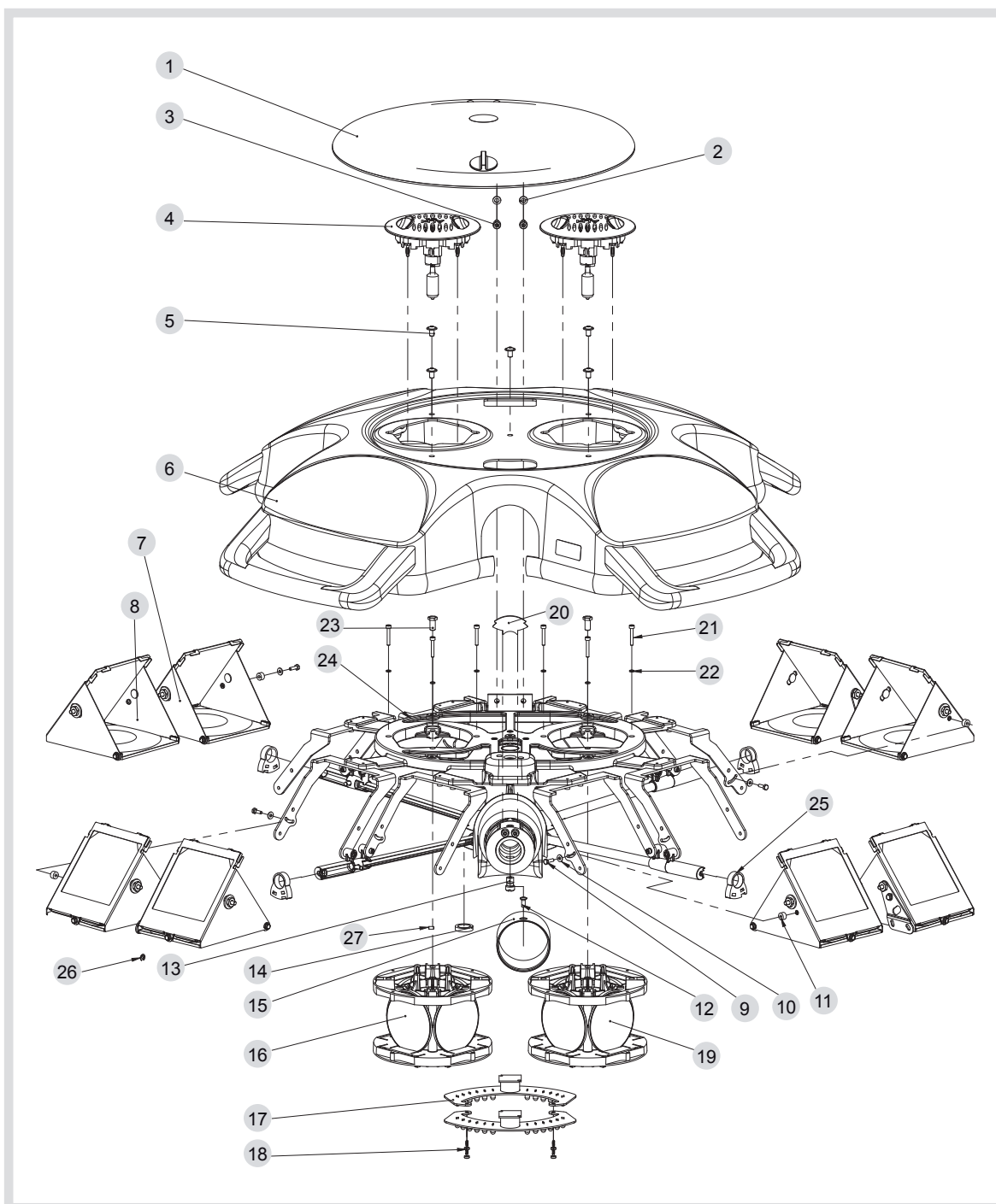

PART LIST 8

HANDLES AND UNDERSIDE

No.	Part number	Description	Qty
	367811998	S/A Underside (Serial no. < 20,000)	1
1	567801021	Underside	1
3	600410408	M4x8 FHc screw	4
	367834555	S/A Underside (Serial no. > 20,000)	1
1	567801164	Inner underside	1
2	567801165	Outer underside	1
3	600410408	M4x8 FHc screw	4
	367837555	S/A underside (May 2009)	1
1	567801180	Inner underside	1
3	600410408	M4x8 FHc screw	4
4	567501253	Devon handle option	1
5	567702909	OSD Zoom-lens PAL camera	1
	567702910	OSD Zoom-lens NTSC camera	1
6	567801986	S/A orange tilt handle	1
7	567203952	PAL V4 fixed focal length camera	1
	567203953	NTSC V4 fixed focal length camera	1
8		Devon handle	1
9	567203132	Sterile handle option for zoom-lens camera	1
10	367840998	Sterile handle	1
11	367203975	Sterile handle option for CFF camera	1

DIAGRAM 8

HANDLES AND UNDERSIDE

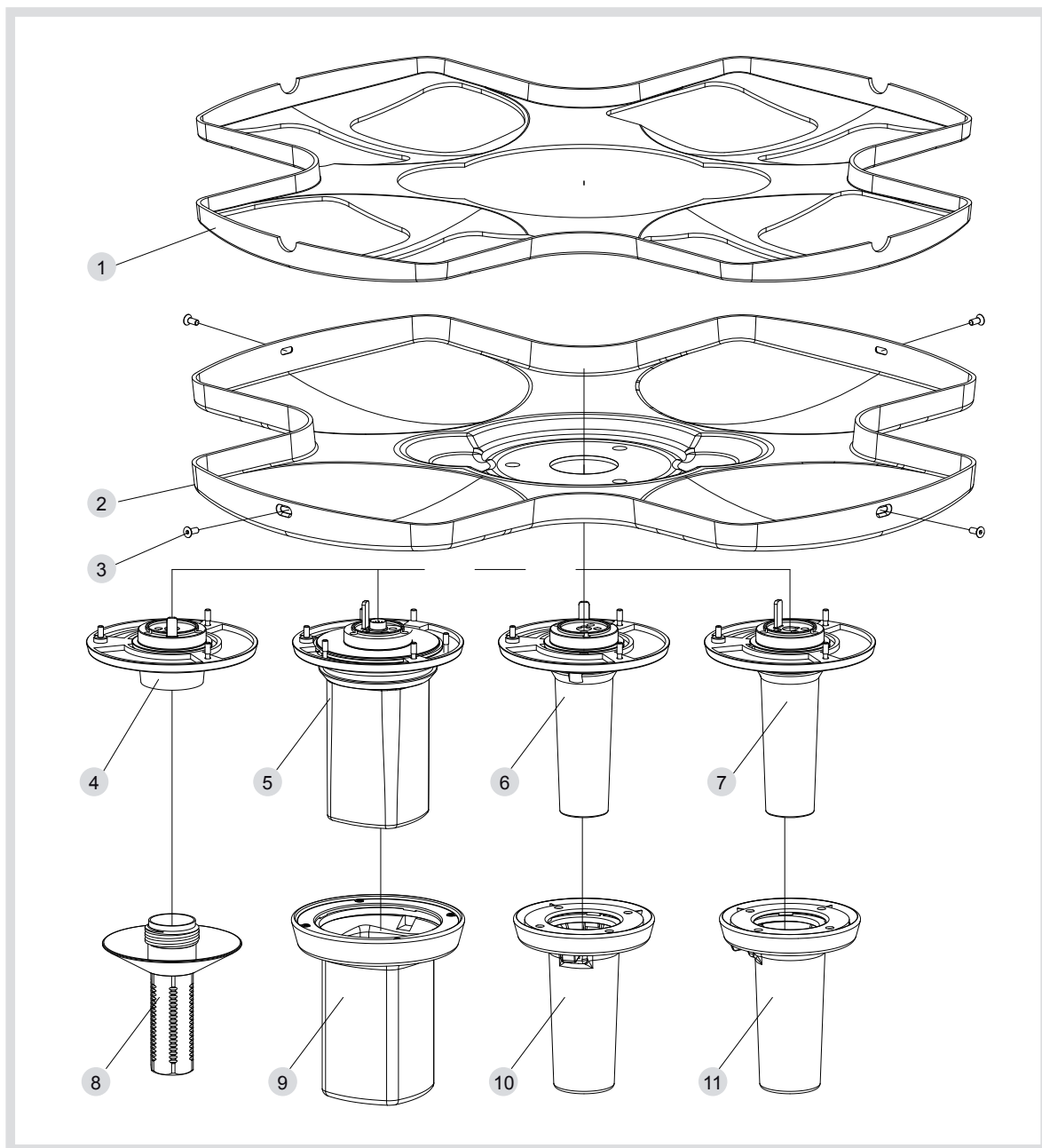

PART LIST 9

S/A LIGHTHEAD WING (STANDARD OR VIDEO)

No.	Part number	Description	Qty
	367838555	Kit of XTen seals	1
1	567801029	Fork seal	1
5	567801203	Grey underside seal grey (May 2009)(see parts list 10)	1
2	623602512	Needle bush HK 2512	1
3	623602005	Needle bush HK 2212	1
4	600530510	M5x10 Socket head cap screw	4
5	604664308	0mm lg8 pop rivet	2
6	567801015	Female plug	4
7	567801089	Insulating washer	4
8	567801007	Optical mounting plate	1
9	567801014	Insulating bush	4
10	567801076	Beam for lighthouse	1
11	602600410	W6 Grower washer	4
12	601410603	Hm M6 nut	4
13	567801054	Spacer welded for baseplate	1
	367814998	S/A control rod	1
14	600990081	PT K30x8 WN5452 screw	7
27	600530316	M3x16 Socket head cap screw	8
28	567801998	S/A control rod	4
29	601320324	Hu M3 nut	8
15	567801077	Video beam - coelio	1
16	567501207	Video connector washer	1
17	601320432	Hu M4 nut	1
18	567801008	Cam mounting plate	1
	367833555	XTen mirror bracket repair kit (x8)	1
19	602390306	3 mm star washer	32
25	567801013	Mirror bracket	8
26	600520308	M3x10 Socket head cap screw	18
20	600990084	Torx TC M3x12 screw	3
21	567801012	Cam	1
22	600990078	ULF M4x20 screw	1
23	656205200	Spring for S5 200 latch	1
24	567801088	Attachment sheet	1
30	567801100	Spacer	1
31	567801045	Hinge	1
32	602420595	D5 Star washer	2
33	600530320	M3x20 socket head cap screw	3

DIAGRAM 9

S/A LIGHTHEAD WING (STANDARD OR VIDEO)

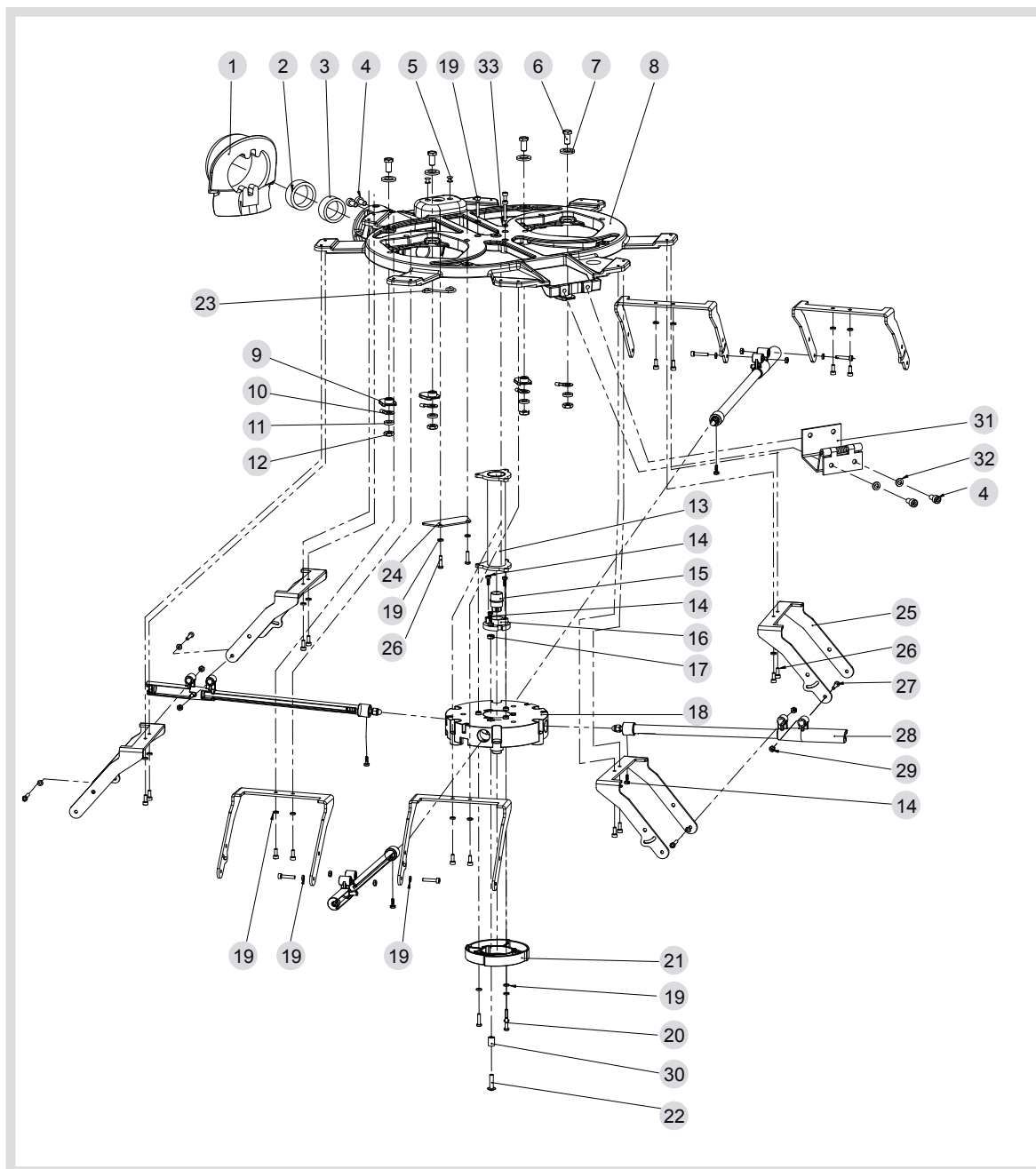

PART LIST 10

S/A SHELL

No.	Part number	Description	Qty
1	567801026	Shell	1
	367838555	Kit of XTen seals	1
5	567801203	Grey underside seal (May 2009)	1
	567801029	Fork seal (see parts list 9)	1
	367839555	S/A grey grip handles	1
2	567801202	Handle (May 2009)	1
3	601230002	PT K50x25 WN1452 screw	2
4	567801048	Boss for handle	2
6	567801099	Support bracket	1

DIAGRAM 10

S/A SHELL

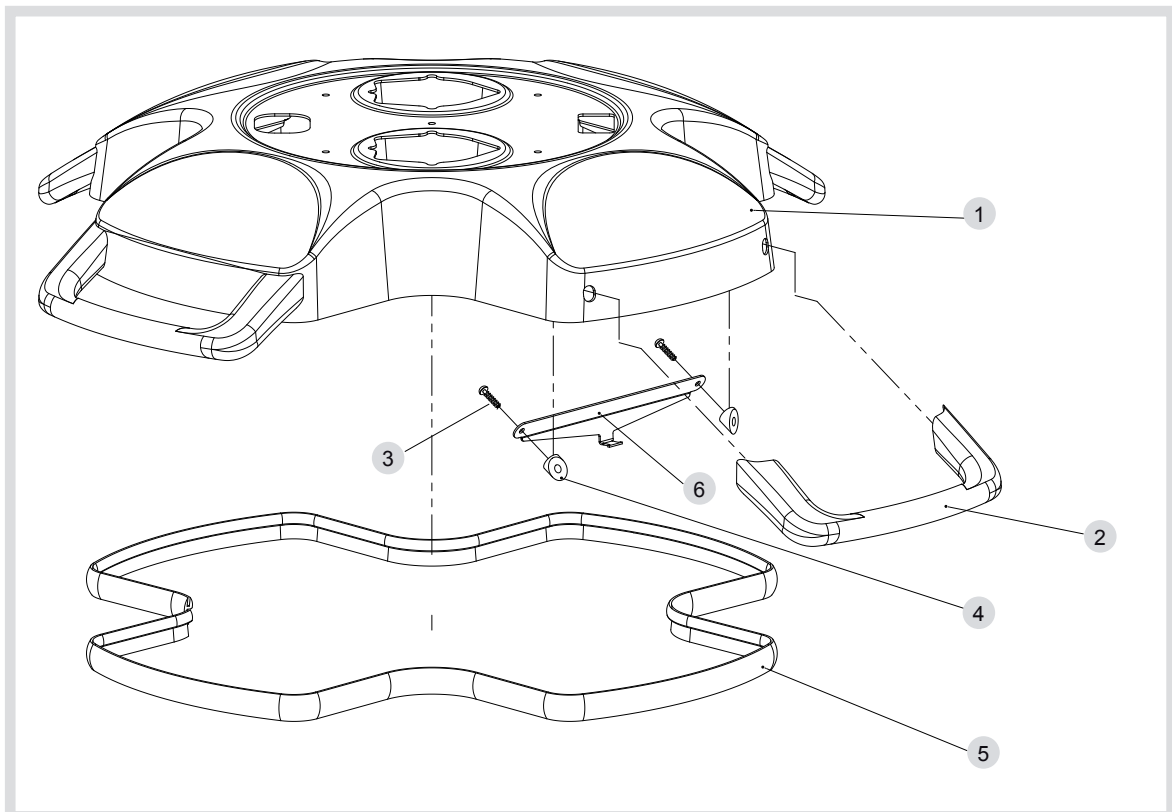

PART LIST 11

S/A COVER

No.	Part number	Description	Qty
	367810998	XTen S/A cover	1
1	567202392	Cover	1
2	567202276	Cast-moulded Button	1
3	567202405	Cover seal	1
4	567202275	Hazard label	1
5	567501196	Hot label	1
6	567202005	Differential washer	1

DIAGRAM 11

S/A COVER

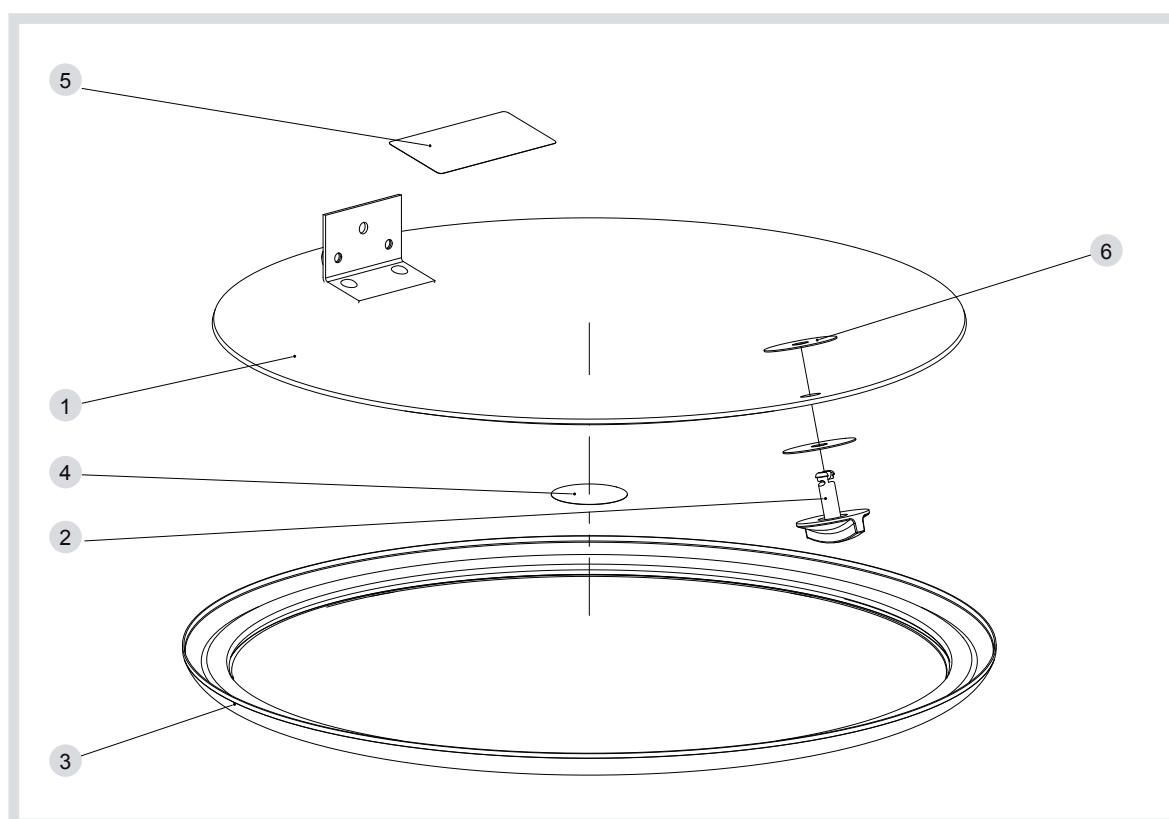

PART LIST 12

S/A CONDENSER (SERIAL NO. < 20,000)

No.	Part number	Description	Qty
	367821998	S/A right condenser (serial no. < 20,000)	1
1	567502002	Central filter	1
2	600990110	M5x16 screw	2
3	567801049	Spacer for lens and filter	2
4	567801103	Central lens without micro-lens	1
5	567501234	Lower lens bracket	1
6	104401	Lower lens	4
7	104400	Outside lens	4
8	601320324	Hu M3 nut	3
9	601410603	Hm M6 nut	1
10	567801047	Upper lens bracket	1
11	600990100	PT K40x40 screw	4
	367822998	S/A left condenser (serial no. < 20,000)	1
1	567502002	Central filter	1
2	600990110	M5x16 screw	2
3	567801049	Spacer for lens and filter	2
4	567801103	Central lens without micro-lens	1
5	567501234	Lower lens bracket	1
6	104401	Lower lens	4
7	104400	Outside lens	4
8	601320324	Hu M3 nut	3
9	601410603	Hm M6 nut	1
10	567801047	Upper lens bracket	1
11	600990100	PT K40x40 screw	4

DIAGRAM 12

S/A CONDENSER (SERIAL NO. < 20,000)

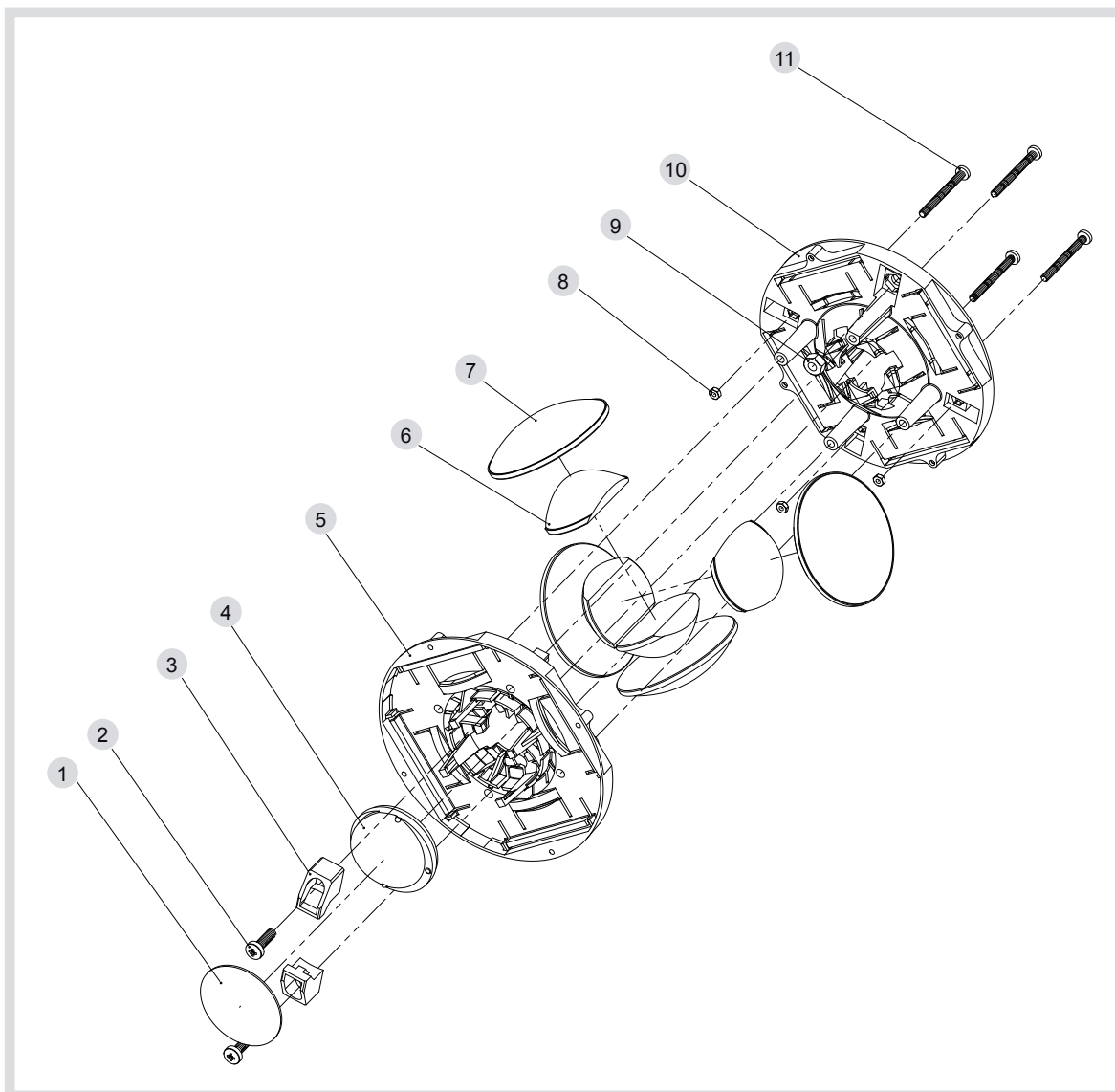

PART LIST 13

S/A CONDENSER (SERIAL NO. > 20,000)

No.	Part number	Description	Qty
	367835998	S/A right condenser (serial no. > 20,000)	1
1	567502002	Central filter	1
2	600990110	M5x16 screw	2
3	567801049	Spacer for lens and filter	2
4	567801103	Central lens without micro-lens	1
5	567501234	Lower lens bracket	1
6	104401	Lower lens	4
7	567501307	Outside lens	4
8	601320324	Hu M3 nut	3
9	601410603	Hm M6 nut	1
10	567801047	Upper lens bracket	1
11	600990100	PT K40x40 screw	4
	367836998	S/A left condenser (serial no. > 20,000)	1
1	567502002	Central filter	1
2	600990110	M5x16 screw	2
3	567801049	Spacer for lens and filter	2
4	567801103	Central lens without micro-lens	1
5	567501234	Lower lens bracket	1
6	104401	Lower lens	4
7	567501307	Outside lens	4
8	601320324	Hu M3 nut	3
9	601410603	Hm M6 nut	1
10	567801047	Upper lens bracket	1
11	600990100	PT K40x40 screw	4

DIAGRAM 13

S/A CONDENSER (SERIAL NO. > 20,000)

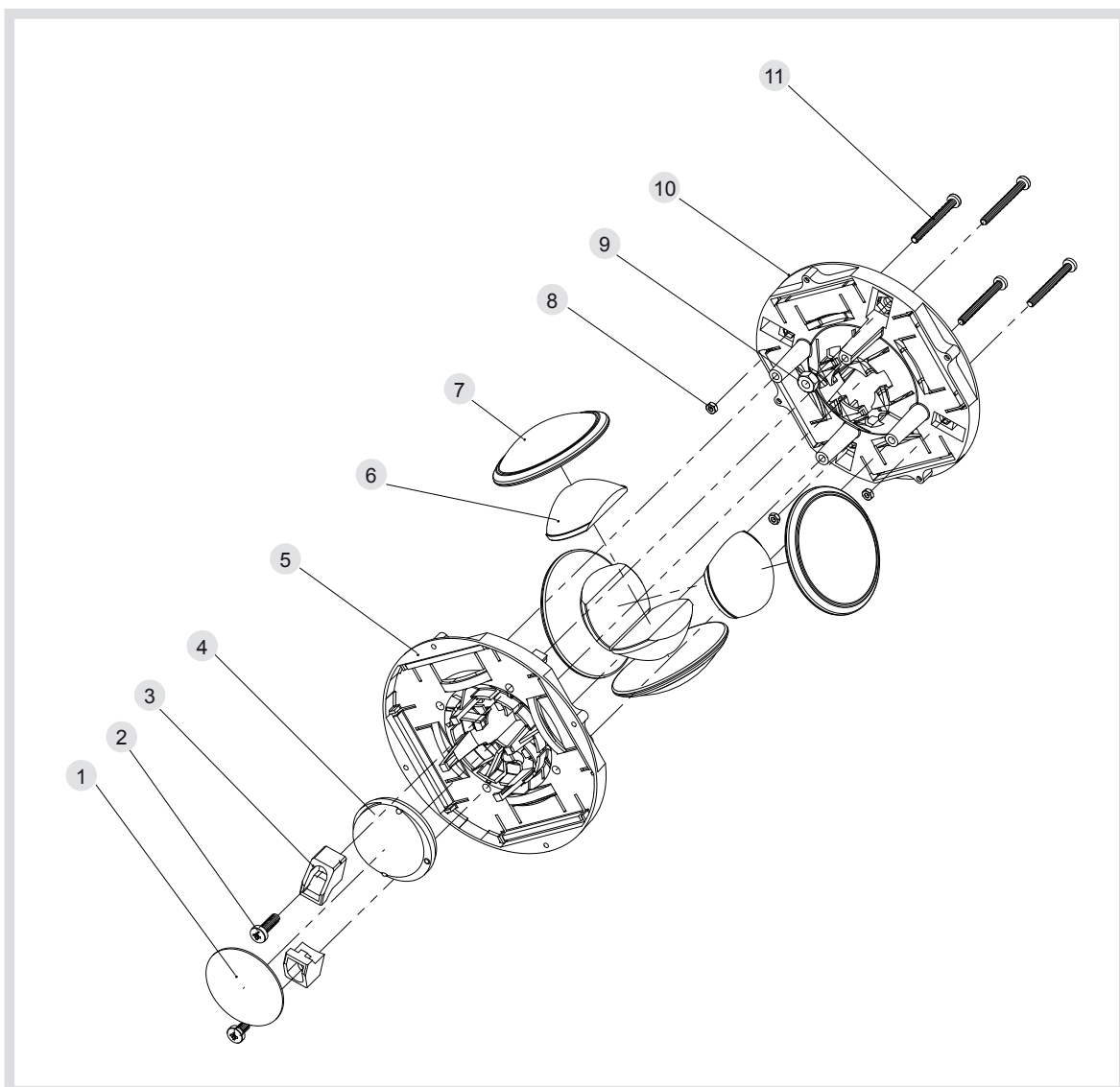

PART LIST 14

S/A FIXED MIRROR

No.	Part number	Description	Qty
	367820998	S/A fixed mirror	1
1	567801039	Power	1
2	639802013	Truarc 5 mm ring	5
3	77691	Shaft nut	2
4	567801053	Mirror bracket shaft	2
5	567501306	Mirror	1
6	602321262	Z6 washer	2
7	567801163	Mirror bracket	1

DIAGRAM 14

S/A FIXED MIRROR

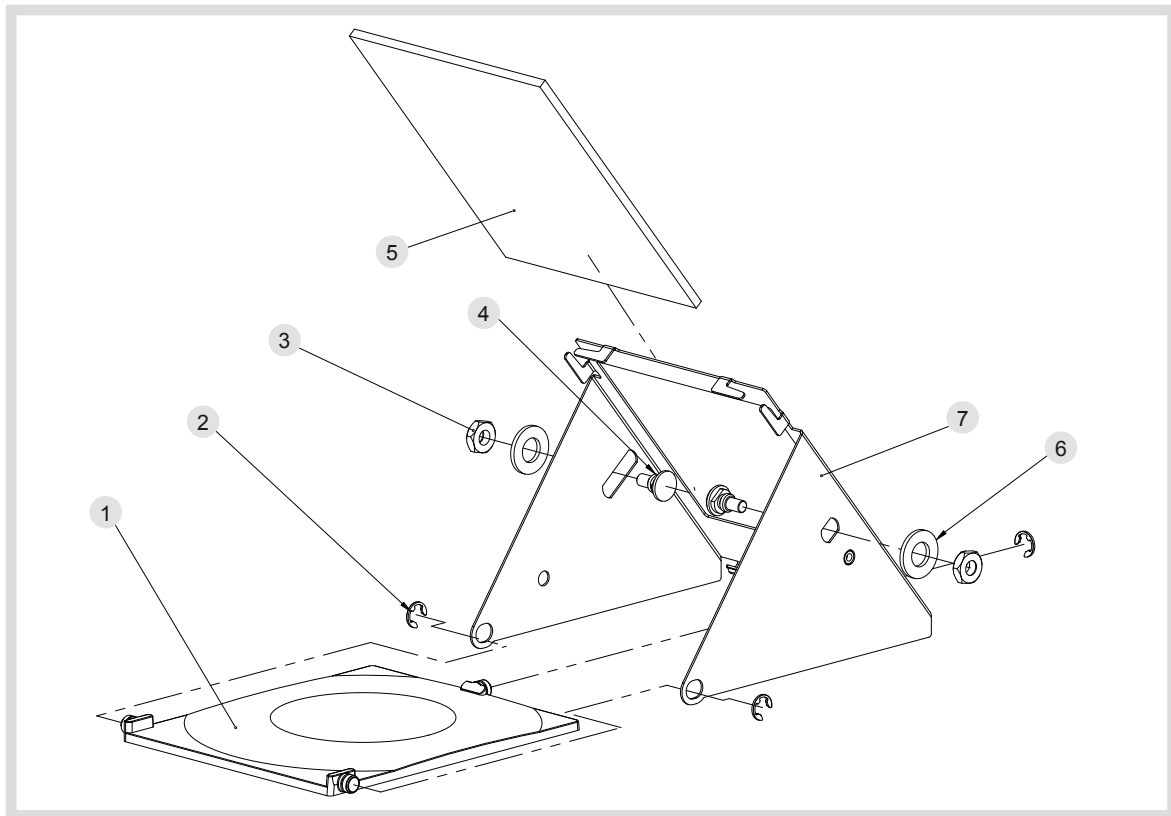

PART LIST 15

S/A MOBILE MIRROR

No.	Part number	Description	Qty
	367823998	S/A mobile mirror	1
1	567801039	Power	1
2	639802013	Truarc 5 mm ring	5
3	601410603	Hm M6 nut	2
4	567801106	Mirror bracket shaft	2
5	567501306	Mirror	1
6	602321682	Z8 washer	1
7	567801163	Mirror bracket	1
8	567801017	Lever	1
9	602120832	M3 washer	1
10	600430312	TH M3 X 12 screw	1

DIAGRAM 15

S/A MOBILE MIRROR

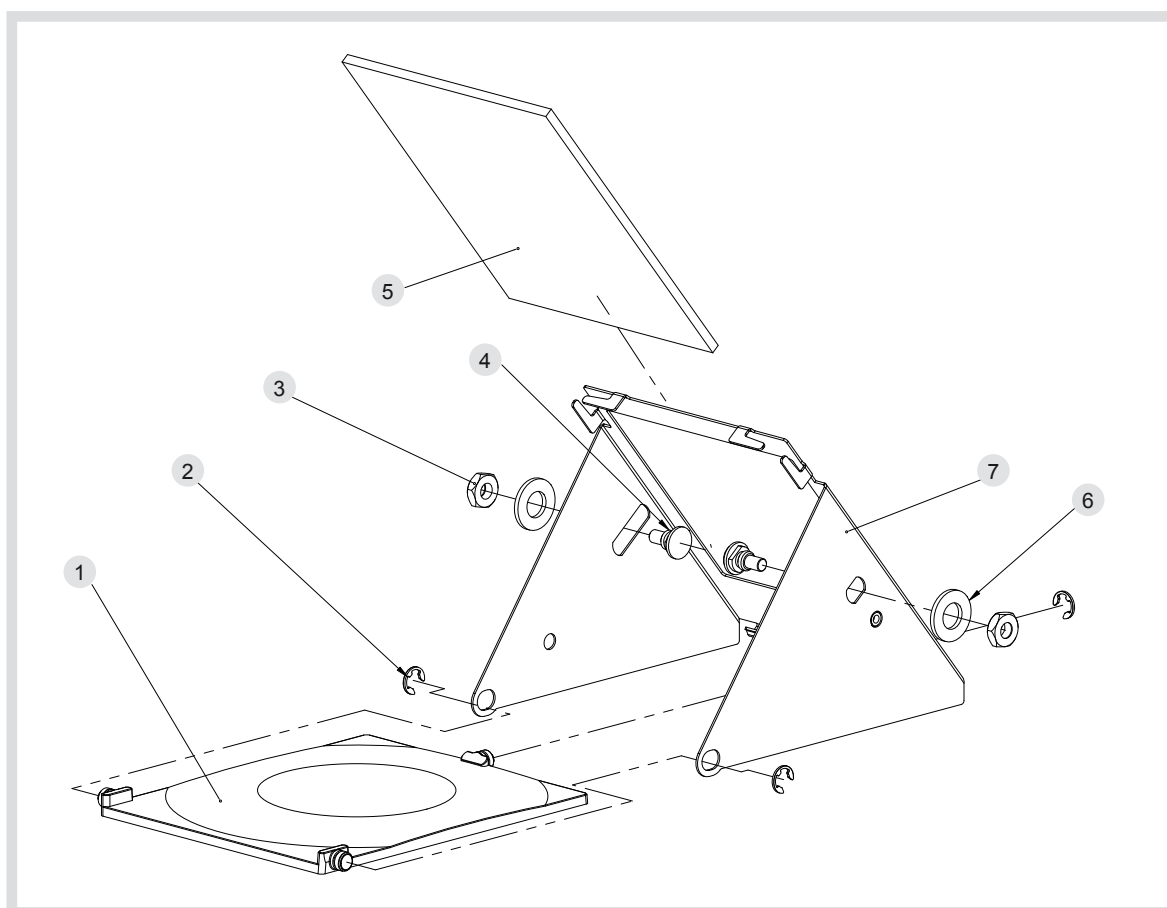

PART LIST 16

CONTROL ROD

No.	Part number	Description	Qty
	367814998	S/A control rod	
1	601320432	Hu M4 nut	1
2	567801004	Bush	1
3	567801043	Spacer mirror bracket	1
4	567801003	Rod	1
5	567801102	Spring	1
6	601560408	M4 cap safety nut	1

DIAGRAM 16

CONTROL ROD

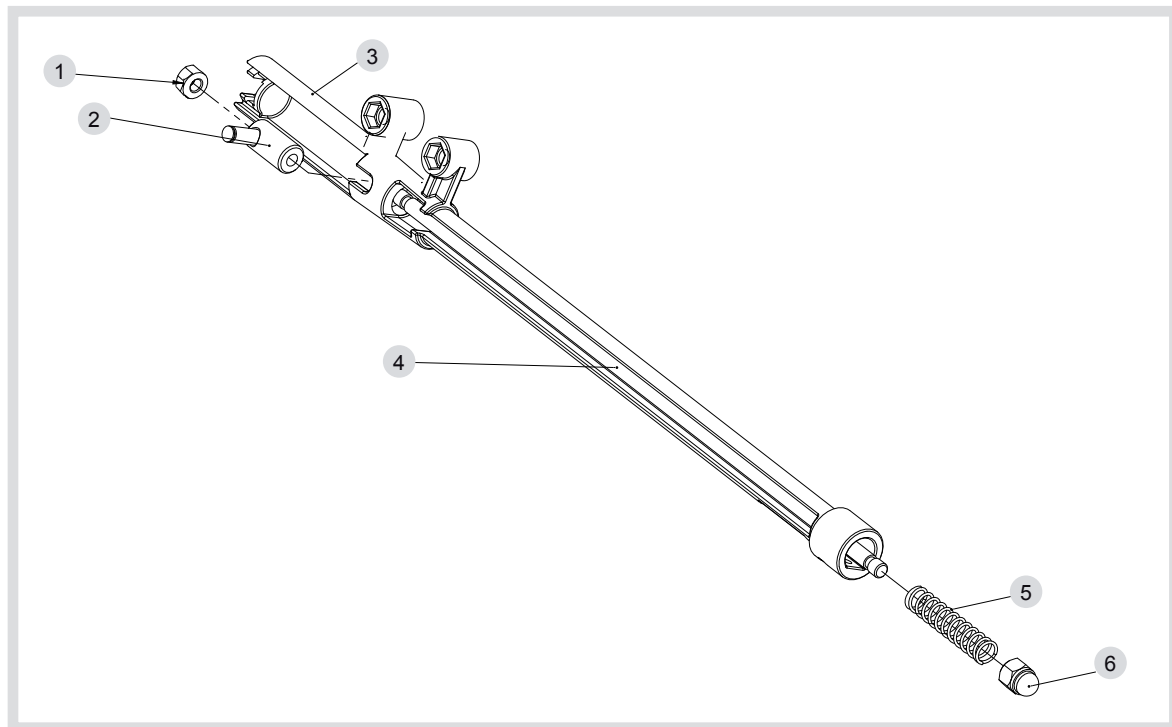

PART LIST 17

BULB HOLDER

No.	Part number	Description	Qty
	367501950	Equipped bulb holder	1

DIAGRAM 17

BULB HOLDER

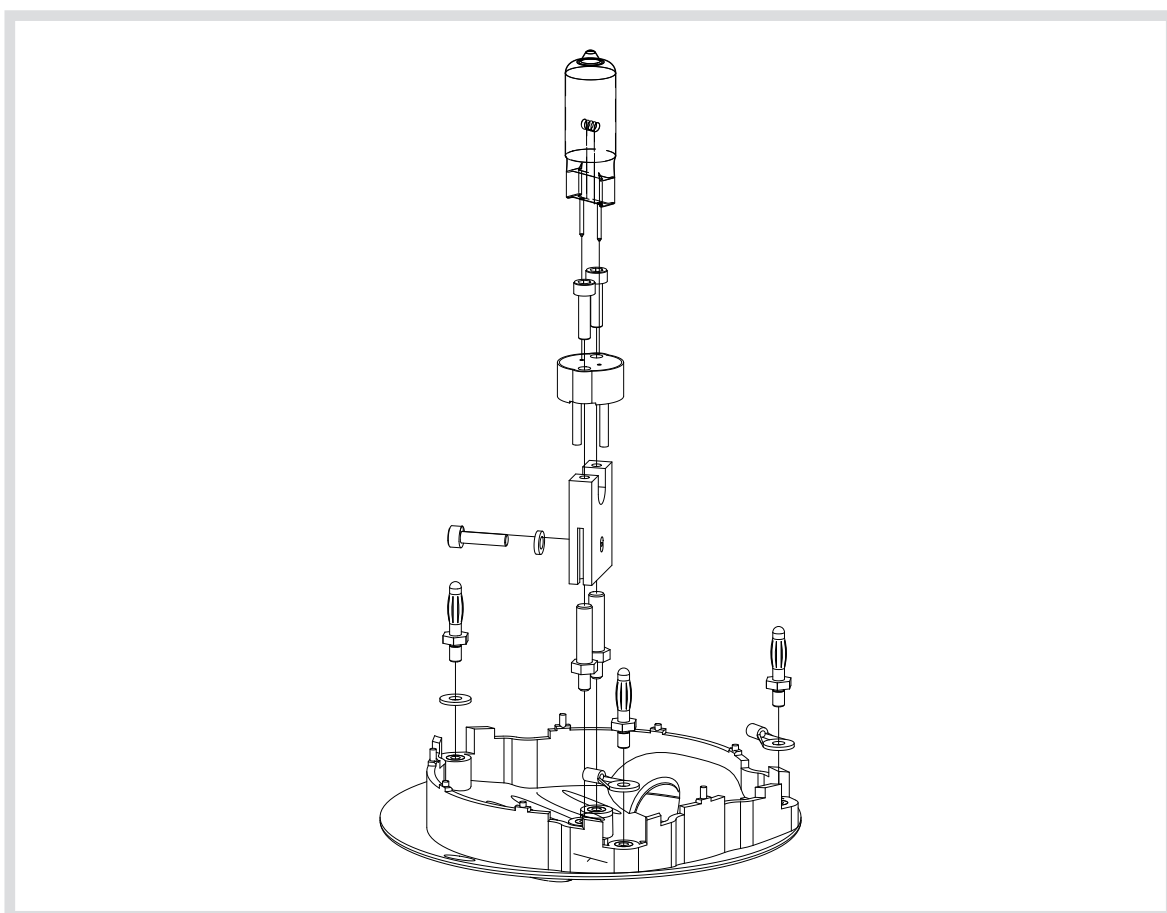

PART LIST 18

S/A TILT HANDLE

No.	Part number	Description	Qty
	367840998	XTen S/A tilt handle	1
1	600990081	PT K 30x8 WN5452 screw	3
2	567801046	Tilt sleeve washer	1
3	568801074	Orange handle	1
4	567501256	Friction washer	2
5	568801080	Base plate	1
6	567801051	Captive screw	3

DIAGRAM 18

S/A TILT HANDLE

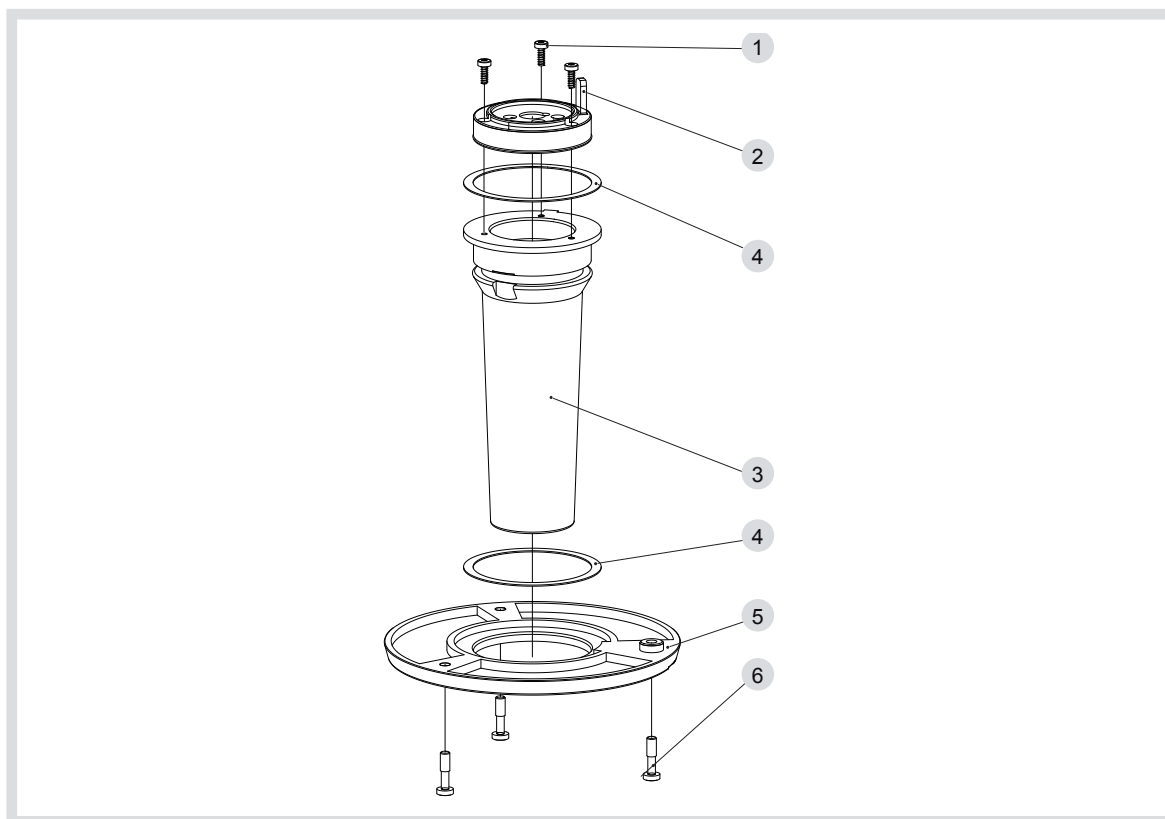

9 CIRCUIT DIAGRAMS

9.1 STANDARD LIGHTHEAD WIRING

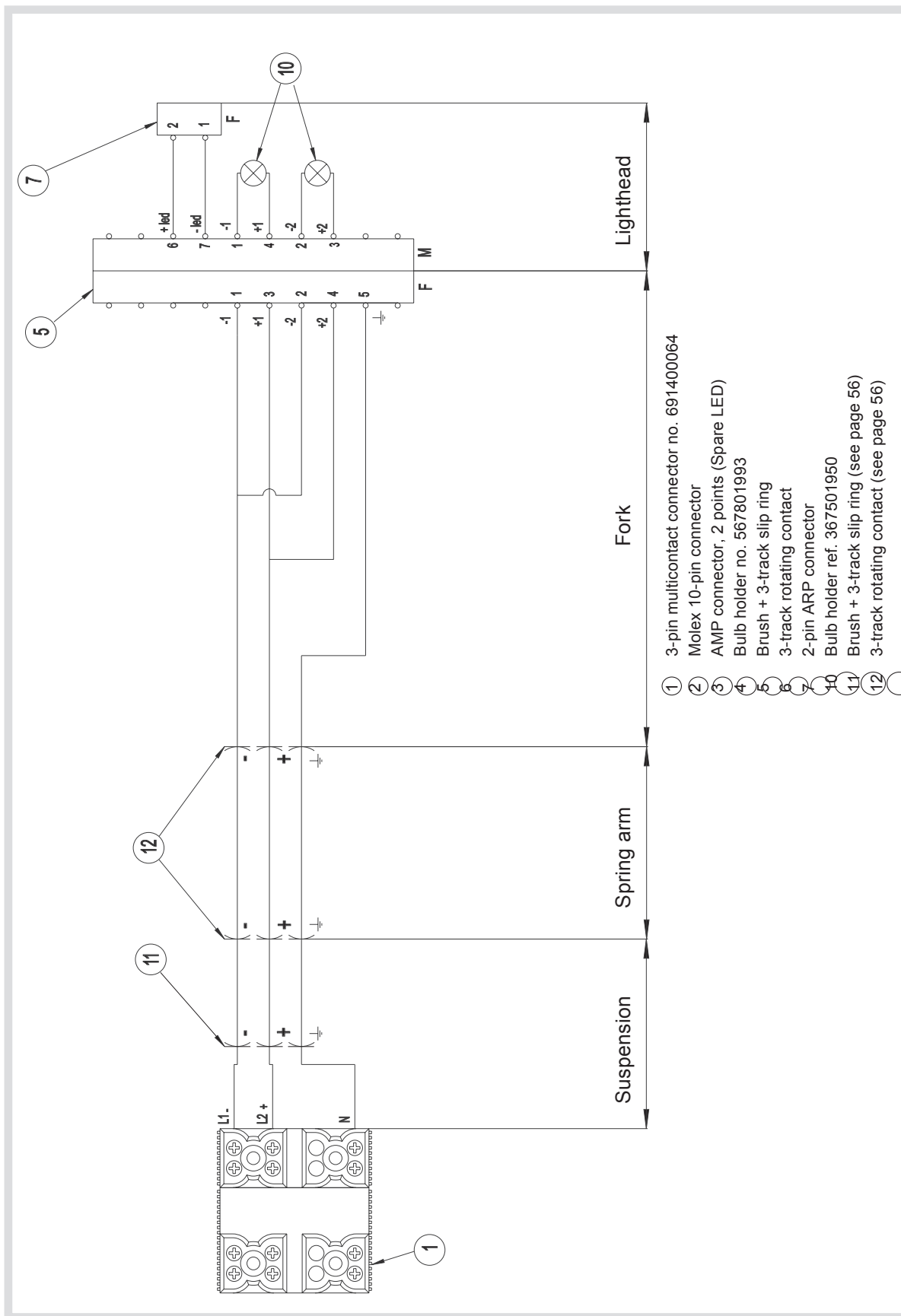

9.2 LIGHTHEAD WIRING WITH AMBIENT LIGHTING

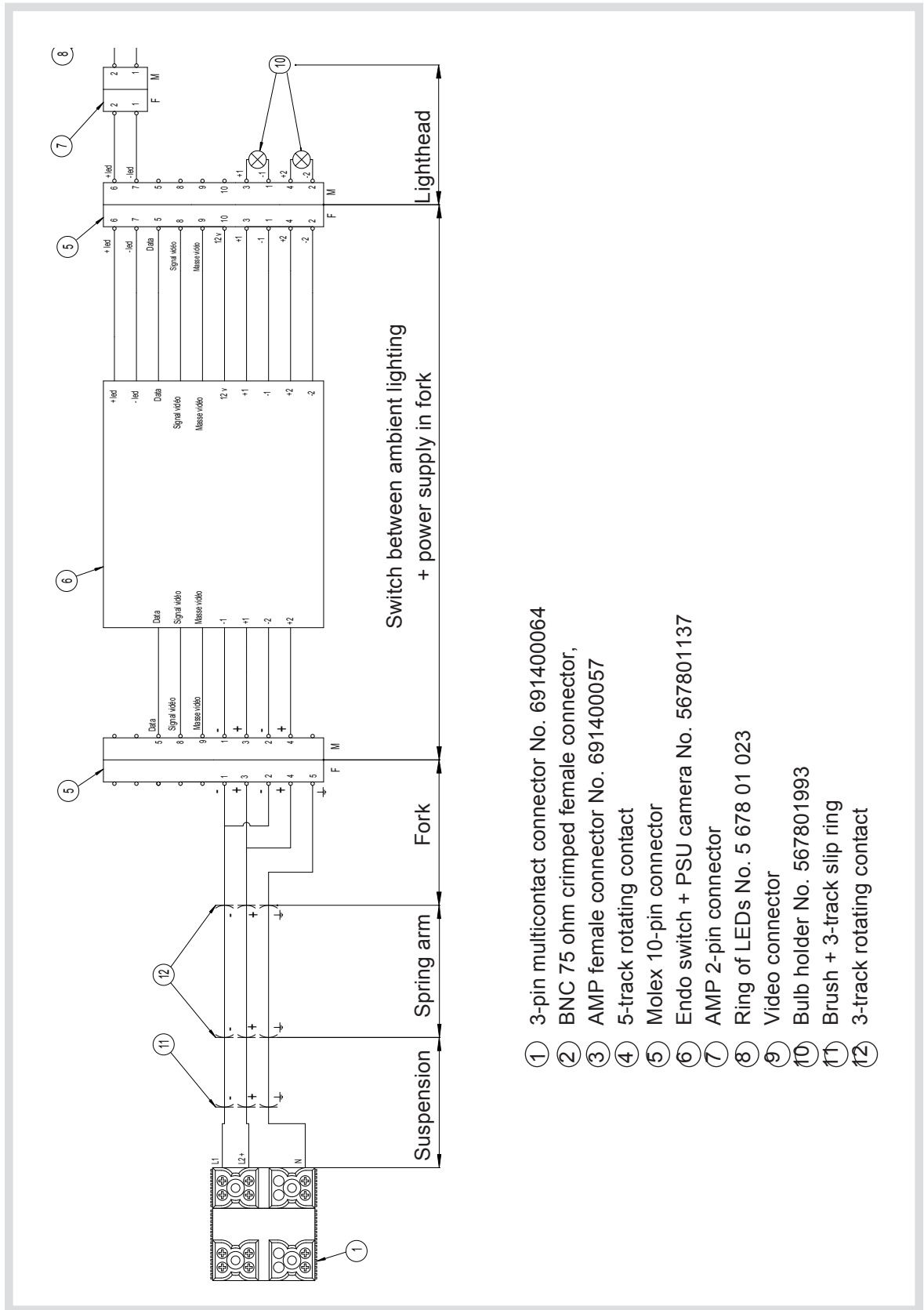

9.3 LIGHTHEAD VIDEO WIRING

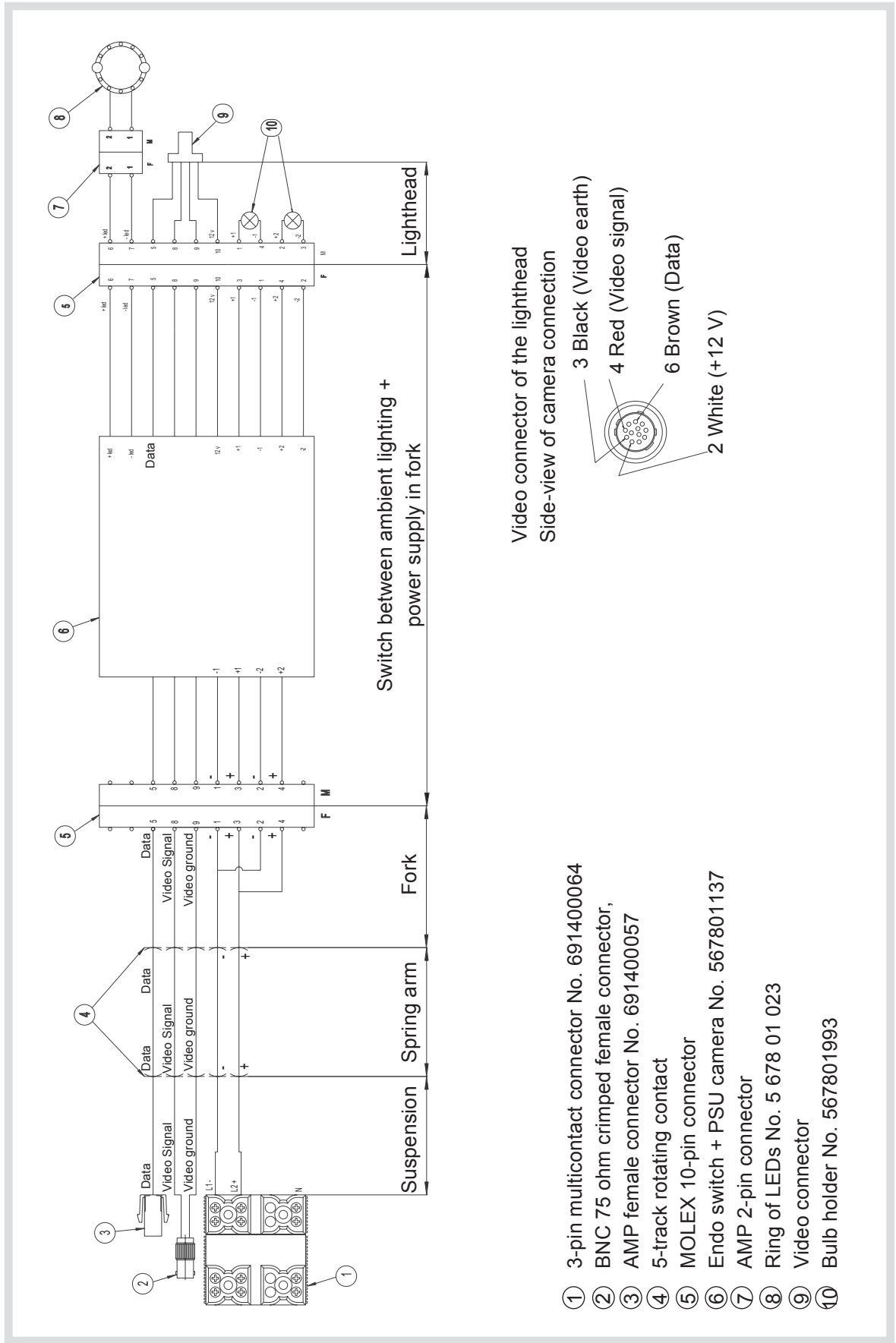

9.4 AMBIENT LIGHTING CONTROL SWITCH

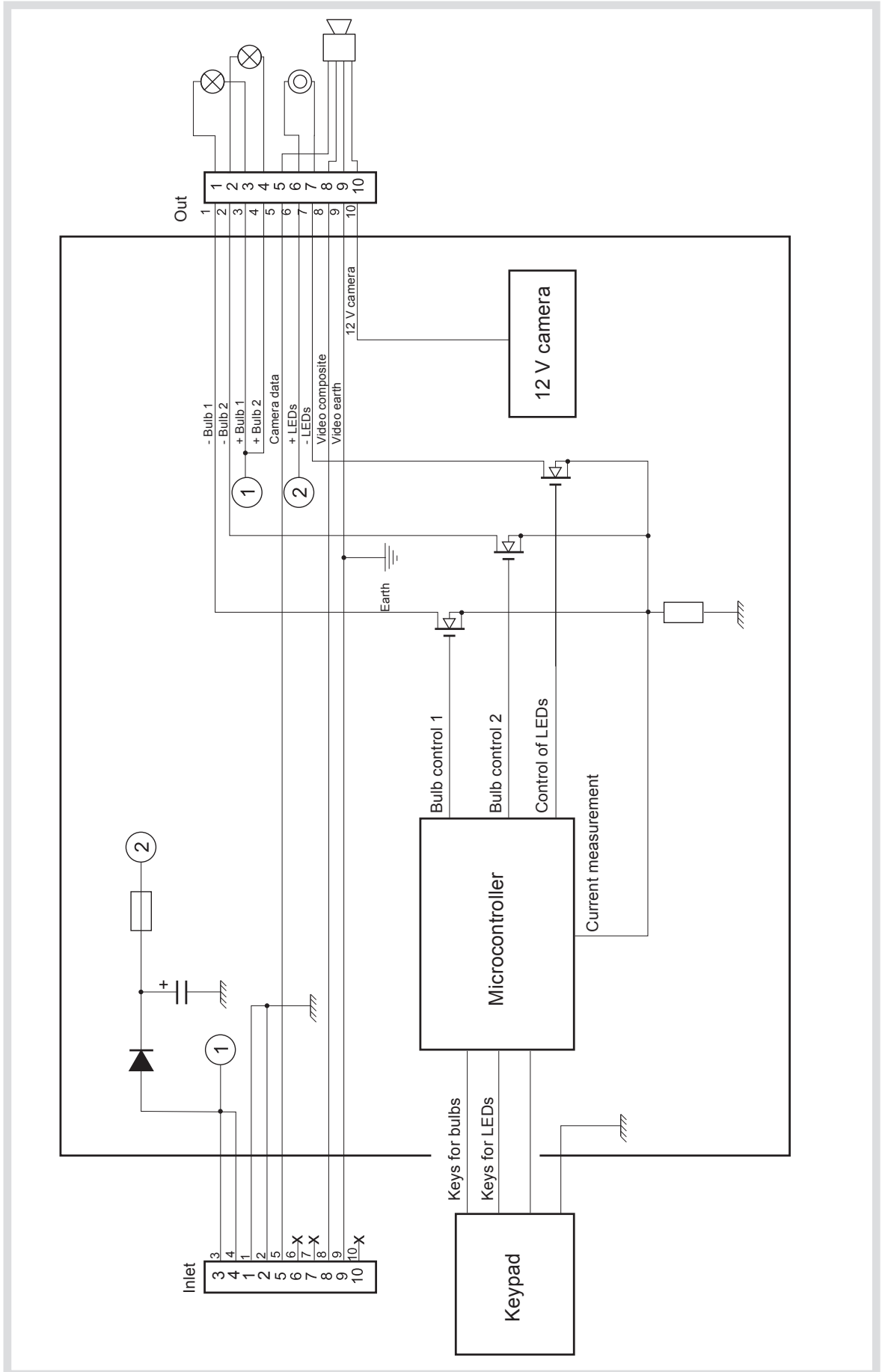















10 TROUBLESHOOTING



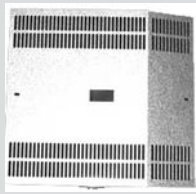
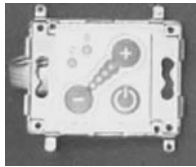

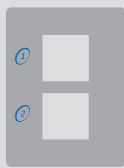
Problem	Likely cause	Corrective action
<ul style="list-style-type: none"> ■ The lighthead does not turn on 	<ul style="list-style-type: none"> ■ Faulty or missing bulb 	<ul style="list-style-type: none"> ■ Cut off the power supply and replace the bulb(s)
	<ul style="list-style-type: none"> ■ Power cut 	<ul style="list-style-type: none"> ■ Check if other devices on the same supply network are operating.
	<ul style="list-style-type: none"> ■ Other reason 	<ul style="list-style-type: none"> ■ Call Maquet technical department
<ul style="list-style-type: none"> ■ None of the lighthead light up 	<ul style="list-style-type: none"> ■ Each lighthead has its own control 	<ul style="list-style-type: none"> ■ Check the LED on the keypad on each lighthead (green LED)
<ul style="list-style-type: none"> ■ The lighthead does not turn on; only ambient light operates 	<ul style="list-style-type: none"> ■ Faulty or missing bulb 	<ul style="list-style-type: none"> ■ Switch off power supply and replace bulb(s)
	<ul style="list-style-type: none"> ■ Other reason 	<ul style="list-style-type: none"> ■ Call Maquet technical department
<ul style="list-style-type: none"> ■ Ambient light does not turn on 	<ul style="list-style-type: none"> ■ The button is defective 	<ul style="list-style-type: none"> ■ Call Maquet technical department
<ul style="list-style-type: none"> ■ Bulb service life too short 	<ul style="list-style-type: none"> ■ Improper bulb or overvoltage condition 	<ul style="list-style-type: none"> ■ Make sure that you are using the required Maquet bulbs exclusively
		<ul style="list-style-type: none"> ■ Check voltage at the bulb pins: $23.5 V_{AC+DC}^{RMS}$
<ul style="list-style-type: none"> ■ The sterilisable handle does not click into place correctly 	<ul style="list-style-type: none"> ■ Sterilisation parameters (temperature, time) exceeded 	<ul style="list-style-type: none"> ■ Check that the locking mechanism works correctly (there should be a click), and check the entire handle
	<ul style="list-style-type: none"> ■ Its maximum service life has expired or the handle is twisted or bent. 	<ul style="list-style-type: none"> ■ Replace the handle
<ul style="list-style-type: none"> ■ The lighthead drifts 	<ul style="list-style-type: none"> ■ Suspension tube not vertical 	<ul style="list-style-type: none"> ■ Check tube verticality and ceiling structure
	<ul style="list-style-type: none"> ■ Ceiling structure unstable 	<ul style="list-style-type: none"> ■ Call Maquet technical department
	<ul style="list-style-type: none"> ■ Brake incorrectly adjusted 	<ul style="list-style-type: none"> ■ Adjust the brake
<ul style="list-style-type: none"> ■ Lighthead moves too easily or is difficult to move. 	<ul style="list-style-type: none"> ■ Locking screw incorrectly adjusted. 	<ul style="list-style-type: none"> ■ Adjust the brake screw
	<ul style="list-style-type: none"> ■ Insufficient lubrication 	<ul style="list-style-type: none"> ■ Call Maquet technical department

11 ENERGIX CONTROL BOX

11.1 ARTICLE PART NUMBERS

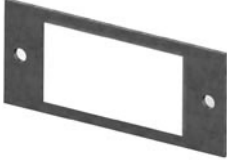
Articles		Code	Part number
Isolated screwdriver (supplied with the product) <ul style="list-style-type: none"> Essential for making adjustments without the risk of causing a short circuit 			
RJ45 crimping tool <ul style="list-style-type: none"> Essential for carrying out RJ45 connections 		RJ crimping tools	5 720 71 999
15 m equipped RJ45 network cable <ul style="list-style-type: none"> Connection cable between PSU and the remote control, bare on one side. 		RJ15M	5 673 13 901
100 m non-equipped RJ45 network cable		RJ100M	5 673 13 902
Standard wire adaptor for RJ45 <ul style="list-style-type: none"> Female connector for adapting and making the connection between an equipped cable of an RJ45 outlet and a bare cable. 		RJ KIT	3 673 16 555
Set of 10 connectors		RJ PLUGS	5 673 13 903
750VA toroidal transformer <ul style="list-style-type: none"> Transformer equipped with a vigitherme which reacts to a temperature of 120°C. 		Tr 750VA	5 673 14 007
450VA toroidal transformer <ul style="list-style-type: none"> Transformer equipped with a vigitherme which reacts to a temperature of 120°C. 		Tr 450VA	5 673 14 002
WPS 2 testing tool <ul style="list-style-type: none"> Measure the outlet current and the different control criteria when fitting with remote display. 		WPS TST	5 720 70 999
0.50 m RJ 45 spiralled cable <ul style="list-style-type: none"> Interconnection cable for connections within the control box. Length 0.50 m 		RJ2OR	5 673 14 008
Finishing cover <ul style="list-style-type: none"> Comprising a finishing box, an adhesive sticker, a display bezel, two dimmer brackets and a hinge kit. 		WPS 2GOLD V2	5 673 07 991

<p>Cover for technical room with display bezel</p> <ul style="list-style-type: none"> ■ Cover comprising a gloss cover and a display bezel. 		<p>WPS 2GOLD V2</p>	<p>5 673 08 991</p>
<p>Lexan panel fitted onto PCB + Legrand mounting plate</p> <ul style="list-style-type: none"> ■ Dimensions of Lexan panel 45x45 mm ■ Finishing spacing of the plate 60 mm ■ Compatible with 2OR covers and RMO controls 		<p>LEXPCB</p>	<p>5 673 14 001</p>
<p>Dimmer kit</p> <ul style="list-style-type: none"> ■ Lexan panel mounted on PCB + dimmer mounting plate 		<p>WPS NG RST</p>	<p>5 673 14 033</p>
<p>Kit of five horizontal stickers</p> <ul style="list-style-type: none"> ■ Replacement sticker for RST wall-mounted remote control 			<p>5 673 20 301</p>
<p>Kit of five vertical stickers</p> <ul style="list-style-type: none"> ■ Replacement sticker for RST wall-mounted remote control 			<p>5 673 20 302</p>
<p>Sticker for finishing box</p> <ul style="list-style-type: none"> ■ Spare sticker for box or remote control 		<p>Sticker for box</p>	<p>5 673 14 019</p>
<p>Display fitted on mounting plate</p> <ul style="list-style-type: none"> ■ Screen dimensions: 41x19 mm ■ Attachment spacing: 61 mm ■ Drilling diameter: 5 mm ■ If installing onto a stainless steel panel (technical room example) drill two countersunk holes and set two Fhc M4 screws (not supplied) 		<p>DSP</p>	<p>5 673 12 997</p>
<p>Lexan bezel fitted on mounting plate</p> <ul style="list-style-type: none"> ■ Cover covered by a sticker ■ Dimensions of bezel: 45x45 mm 			<p>5 673 14 011</p>

<p>Lexan bezel fitted on surface dimmer</p> <ul style="list-style-type: none"> ■ Dimensions of bezel: 45x45 mm ■ Compatible with 20R-V2 covers (ref. 5 673 07 991) and wall-mounted remote (Ref. 5 673 20 999). 			5 673 14 032
<p>Metallic display bezel</p> <ul style="list-style-type: none"> ■ Cover covered by a sticker ■ Attachment spacing: 60 mm ■ Compatible with old and new covers. 			5 673 14 031
<p>180 W controller board</p> <p>400 W controller board</p>		REG 180 REG 400	5 673 14 004 5 673 14 006
<p>Bypass charger board</p> <ul style="list-style-type: none"> ■ Allows switching and battery charge 		CHARGER	5 673 05 990
<p>Double filter board</p>		FILTER	5 673 14 901
<p>Micro-controller board + RS 232</p> <ul style="list-style-type: none"> ■ Emergency display and series connection controller board 		MICRS2	5 673 14 009
<p>Thermoformed battery pack cover</p>			5 673 14 013
<p>Battery repair kit</p> <ul style="list-style-type: none"> ■ Including a set of two pre-assembled 24 V/24 Ah batteries 			5 673 14 024

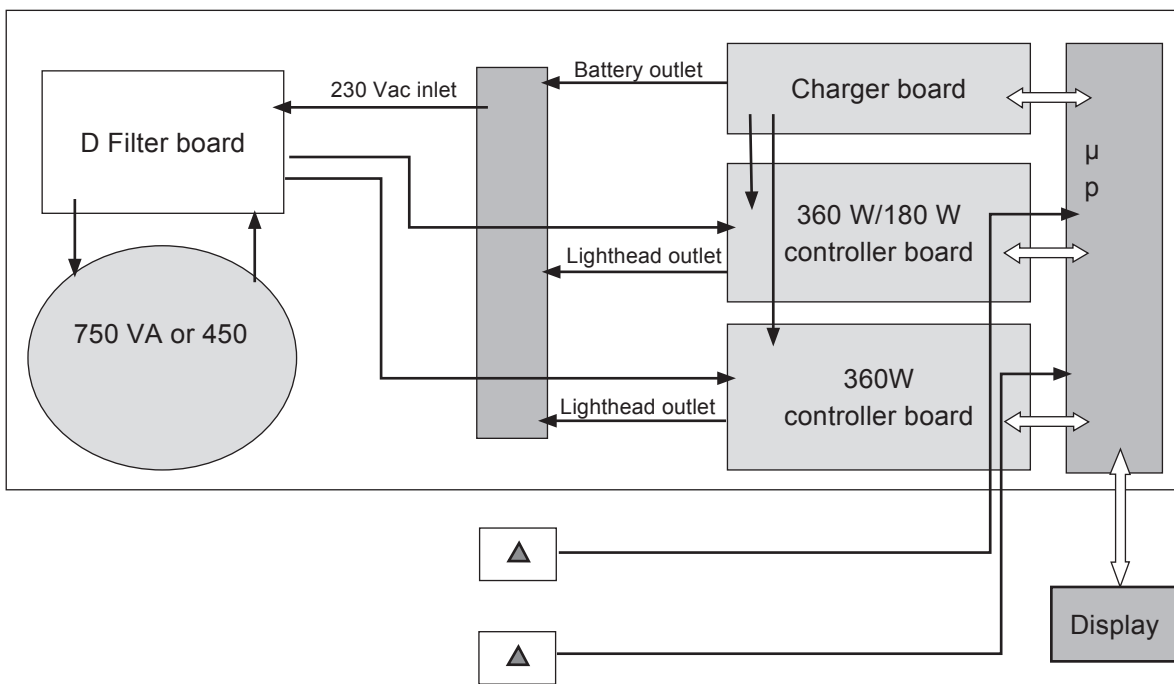
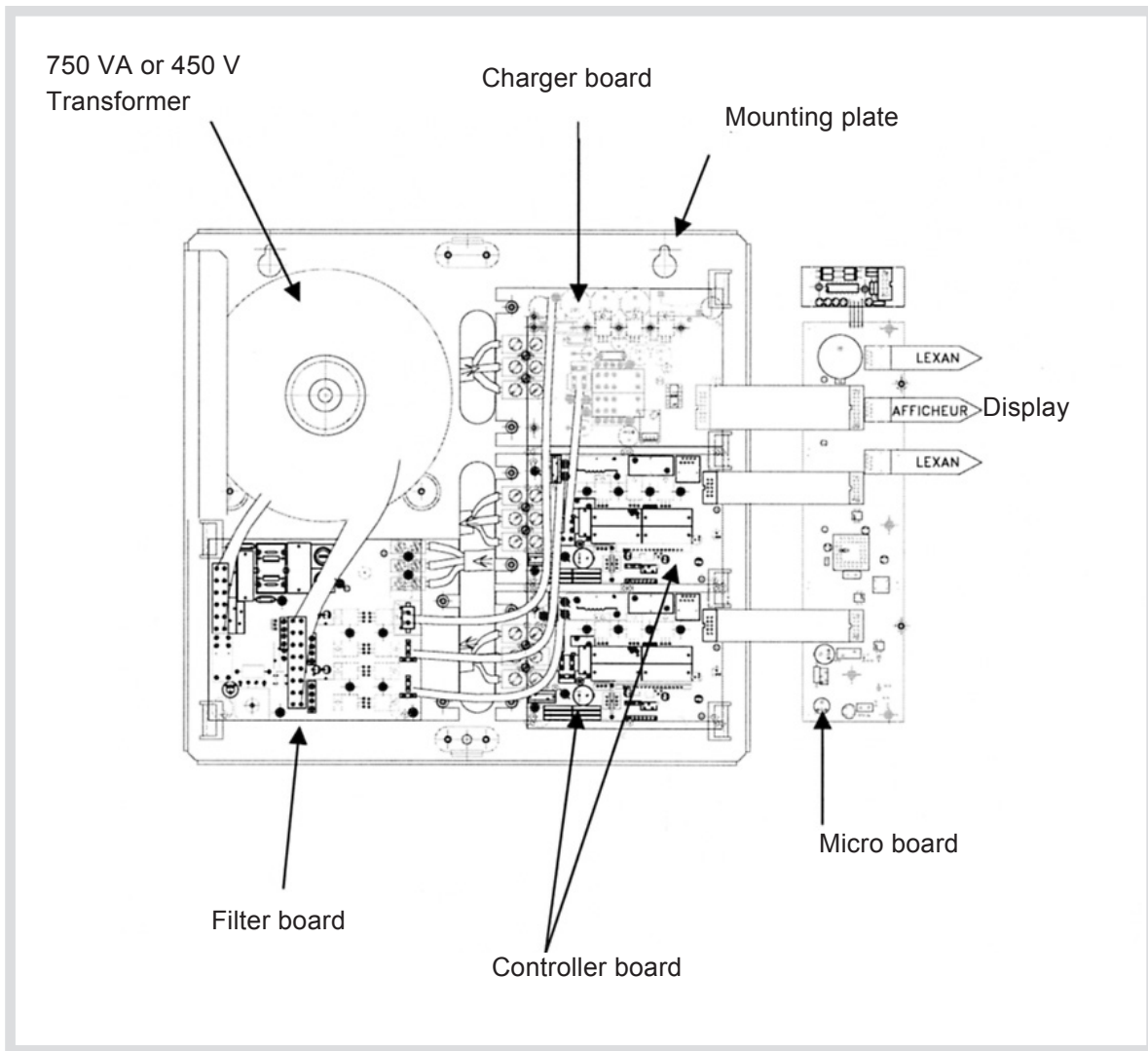

11.2 DESCRIPTION/CHARACTERISTICS

GENERAL

- The WPS modules are stabilised power supplies.
- Each equipped box consists of a 450 or 750 VA transformer, a filter board, one or two controller boards, a bypass charger board, a µC controller board and one or two Lexan panels.
- The management board is capable of storing a very large amount of data: bulb and bulb holder usage time, bracket lamps, maintenance inspections schedules, current/voltage/temperature readings, and so on.
- WPS: Worldwide Power Supply.
- Function: power supply for operating room lighting
- Power: single channel :
 - 100 - 120 -150 W
 - 200 - 240 – 300 - 360 W
- Power: double channel:
 - 2x 100 - 2x 120 - 2x 150 W
 - 2x 200 – 2x 240 – 2x 300 – 2x 360 W
 - + combinations.
- Dimensions (mm): 362 x 342 x 113
- Weight (kg): 10.8 kg with packaging

STANDARDS

- Class 1 type B medical equipment
- These standards are applicable for the entire finished product:

Standards	Levels	Comments
EN 60-601-1		230 V Version
UL 2601-1		110 V Version
EN 55,011	A	EMI
EN 601-1-1-2		Susceptibility
FCC part 15	A	110 V Version

COMPOSITION OF A POWER SUPPLY

- A power supply is made up of separable subassemblies. These boards are connected to each other by connectors. They can easily be removed using a cross-head screwdriver. Therefore in the event of a fault it will be easy to replace the defective sub-assembly.

- 1 Mounting plate
- 2 Toroidal transformer
- 3 Filter board + synchronous rectifier
- 4 One or two regulator boards for current / voltage
- 5 Battery charge board (optional)
- 6 Micro controller board + RS 232 link (optional)
- 7 One or two lighting controls.
- 8 Display (optional)
- 9 Battery pack (optional)

CODING TABLE

W	P	S	X	Y	Z
---	---	---	---	---	---

■ WPS = World Power Supply

■ First digit

X = 2 First module fitted with 150 Wmax = WPS 2

X = 4 First module fitted with 360 Wmax = WPS 4

■ Second digit

Y = 2 Second module fitted with 150 Wmax (e.g. WPS 22)

Y = 4 Second module fitted with 360 Wmax (e.g. WPS 44)

■ Third digit

Z = 0 Without charger nor controller board fitted (e.g. WPS 420)

Z = 1 RS232 management board + display and charger fitted (e.g. WPS 421)

Z = 3 RS232 management board + display without emergency controller board fitted (e.g. WPS 423)

■ Example:

WPS 400 for X'TEN lighting without emergency option

WPS 401 for X'TEN lighting with emergency option

WPS 403 for X'TEN lighting with serial link control

Ref.	Compatibility	Data	ON/OFF	Micro board (1)	Display (2)	Switch (3)	Inter.Batt. (4)	Wall-mounted remote	USA remote	Surface-mounted assembly	WPS IRC Option
WPS 400	X10 DF	360 Watt	X					X	X	X	X
WPS 401	X10 DF	360 Watt	X	X	X	X	X	X	X	X	X
WPS 403	X10 DF	360 Watt	X	X	X			X			X
WPS 420	X10+AXL	360+150 Watt	X					X	X	X	X
WPS 421	X10+AXL	360+150 Watt	X	X	X	X	X	X	X	X	X
WPS 423	X10+AXL	360+150 Watt	X	X	X			X	X	X	X
WPS 440	X10 DF DUO	2 X 360 Watt	X							X	X
WPS 441	X10 DF DUO	2 X 360 Watt	X	X	X	X	X		X	X	X
WPS 443	X10 DF DUO,	2 X 360 Watt	X	X	X			X	X	X	X
WPS RMO								X			
WPS RUS									X		
WPS RST								X	X		
WPS 20R										X	
WPS 2TR								X			

- 1 Display management and RS232 serial port
- 2 LCD screen
- 3 Switch on batteries in the event of power failure
- 4 Battery link kit (batteries sold separately - PB 24 V 24 Ah.

SPECIFICATIONS OF WPS CASE

Mechanical

- Aluminium case with cover + RAL 9016 Paintwork (WPS 20R).
- Dimensions 362 x 342 x 113 (W x H x D)
- Plate attached by two holes
- Cover attached by two screws on front panel

Thermal

- Operation range 10° to 40°C (ambient)
 - Storage temperature -25 to + 70°C
- * The ambient temperature is measured 1 cm from the case

Electrical

- Switch mode power supply (see drawing).

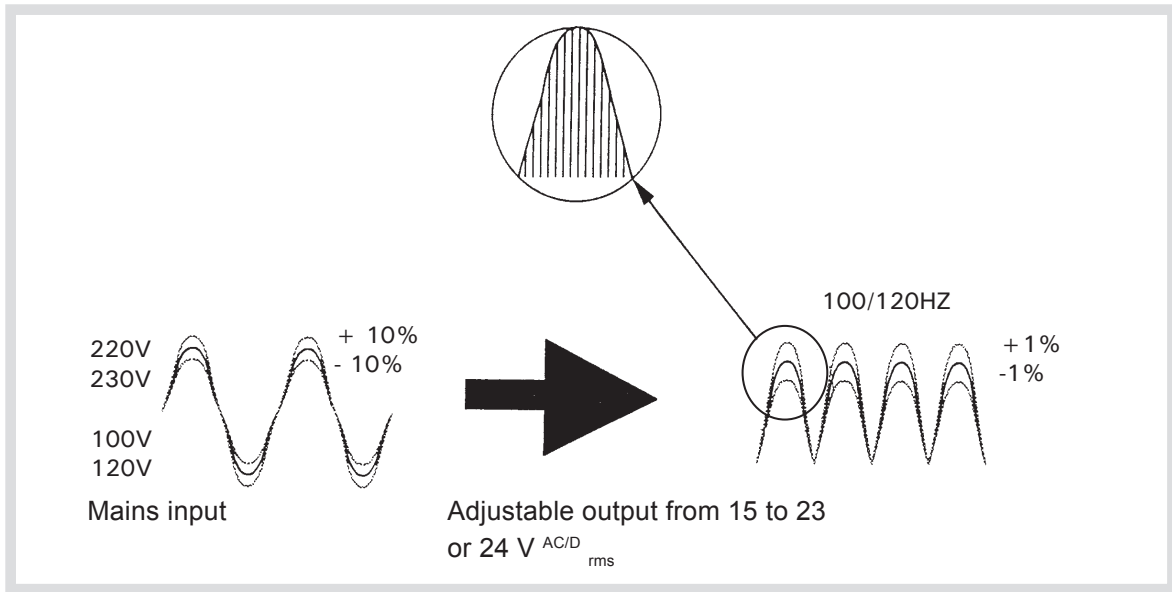

SPECIFICATIONS OF 24 AH BATTERY CASE

Function

- Used to provide lighting power of minimum 40,000 lux for 1 hour
- During the backup period running on batteries the light output level cannot be adjusted
- For high-power configurations (XTen duo = 400 W), it is recommended to connect two battery packs in parallel.

Mechanics

- Zinc-plated steel box
- Dimensions 416 x 180 x 190 (W x H x D)
- Attached with two 8 mm screws

Electrical

- These can be connected either through the top of the case or the back
- The case is fitted with a 32 A terminal block fuse holder (fitted with a 25 A fuse). There are cables connecting the fuse to the two batteries.

Thermal

- Storage temperature -25 to +70°C
- Ambient operating temperature -5°C to +30°C

TRANSFORMER

- Each WPS is fitted with a toroidal transformer with power of 450 VA or 750 VA.
- The transformers include three secondary windings (one per channel) and two primary windings for switching (115/230 V).
- The role of the transformer is to ensure galvanic isolation between the input network and the output voltage, to decrease the input voltage from 230 V to 37 V and thus to optimise efficiency of the secondary modules, and finally to enhance the EMC immunity of the products.
- A thermal fuse is wired in the transformer so as to prevent any risk of destruction.

SPECIFICATIONS OF THE PRIMARY FILTERING BOARD

Function

This board has two functions:

- EMC filtering (conduction = susceptibility) and thus ensures compliance with EMC standards EN 55 022 and EN 60 601.
- The voltage rectifier uses an MOS transistor bridge. This has the advantage of causing very low energy losses. An LED indicates the presence of the 37 V supply on the board. For the charger, the rectifier uses a diode bridge.
- Fuses F3 and F4 protect from overcurrents generated by the controllers.
- Fuses F1 and F2 protect the board from primary overcurrents and also allow the AC supply to be cut whilst maintenance work is being performed.
- Fuse F5 protects against overcurrents and possible inverted battery polarity.

Mechanics

- Bare PCB on aluminium plate
- Format 115 x 160 x 60 mm
- Fastening two 4 mm holes + snap-on installation of fixed terminal block on plate
- Input connection to 10 mm² screw terminal block
- Transformer output by 6.35 mm faston lug
- Rectifier output by 6.35 mm faston lug
- 2-pin AMP charger output
- 3-pin HE13 μ C PSU output
- Two possibilities for supply voltage

Nominal input voltage 110 V AB.

- Input voltage range from 90 to 132 V AC.

Nominal input voltage 230 V AB

- Input voltage range from 198 to 253 V AC

- Frequency range from 47 to 63 Hz
- EMI Protection: By P filter
- Primary/Earth leak current < 500 μ A at 230 V
- Inrush current limitation by phase by CTN:
 - 2.2 Ω for Ve 110 V
 - 4.7 Ω for Ve 230 V
- Current limitation by fuse by phase:
 - (450 VA - 110 V) 8AT
 - (750 VA - 110 V) 16AT
 - (450 VA - 230 V) 8AT
 - (750 VA - 230 V) 8AT
- Protection against overvoltages: Gemov 68ZA 10 on each secondary winding

Output specification

- Nominal output voltage: 37 V rectified (AC+DC)
- Nominal output range 31 V to 41 V rectified (AC+DC)

SPECIFICATIONS OF THE 4 A TO 15 A CONTROLLER BOARD

Function

- These ensure that downline from the secondary rectified voltage, the average output current remains stable and controlled. The secondary voltage is therefore switched at a high frequency (in the order of 50 kHz) by the transistors.
- This ensures that the system is independant of the impedance of the cable. An HF filter limits the conducted and radiated interference. The output voltage is limited to 27.4 V. The light output level is controlled and varied by the Lexan panel keypad. Maximum power is set at two levels per board: 150 W or 360 W depending upon the configuration selected.
- The boards are configurable at a number of power levels:
 100 – 120 –150 W (REG 180)
 200 – 240 – 300 – 360 W (REG 400).
- Input variations +/- 10% give output variations of +/- 1%.

Mechanics

- Bare PCB on aluminium plate.
- Format 82 x 124 x 55 mm.
- Fastening of two 4 mm holes + snap-on installation of fixed terminal block on plate.
- Input connection via 6.35 mm faston lug.
- Output connection to 16 mm² screw terminal block.

Electrical

- Input voltage 37 V rectified VDC
- Frequency range from 94 to 126 Hz
- EMI Protection by L filter
- Overvoltage protection through Gemov
- Output specification
- The different models of boards are configured in the factory (power of lamps).

	Power	Output	Power	Output
	100 W	4 A	240 W	10 A
	120 W	5 A	300 W	12 A
	150 W	6 A	360 W	15 A
XTen →	200 W	8 A		

- Output current adjusted by pulse control.
- Output power adjusted by jumper switch
- Protection against output overvoltages < 27.5 V

Thermal

- Ambient operating temperature -10°C to +40°C
- Storage temperature -25 to +70°C

SPECIFICATIONS OF THE BYPASS CHANGER BOARD

Function

- Charge two 12 V batteries in series in a predefined cycle.
- Charging cycle: Charge at a constant current of 5 A up to 29 V then charge at a floating voltage of 27.4 V.
- Recharging the batteries: same as the charging cycle as soon as a battery has only around 20% charge left. Batteries are charged with the light switched off. The battery's charge is monitored by the μ C board.
- Switching to battery takes less than 0.5 s and either when there is no network or there is a fault in the fitted controllers. This board is installed in in the lighting unit with a backup battery.

Mechanics

- Bare PCB on aluminium plate.
- Format 100 x 145 x 55 mm.
- Fastening of two holes 4 mm holes + snap-on installation of fixed terminal block on plate.
- Input connection to 2-wire soldered bundle + 2-pin AMP connectors.
- Battery input to 16 mm² screw terminal block.
- Battery output to 3-wire soldered bundle + 6.35 mm faston connector.
- μ C output board connected to HE10 connector on μ C board by ribbon cable.

Electrical

- Input voltage 37 V rectified VDC
- Frequency range from 94 to 126 Hz
- EMI protection input by L filter
- Intensity protection via 20 A ATO fuse
- If the network strength weakens to < 190 V, the power supply switches to backup. If there is no backup, the power supply will cut out at approximately 30% less than its nominal value (220-240 V).
- With a 110 V mains supply, these values should be divided by two.

Thermal

- Ambient operating temperature -10°C to +40°C
- Storage temperature -25 to +70°C
- No input and output isolation

SPECIFICATIONS OF THE CONTROLLER BOARD μ C

Function

This is the smart board for the WPS NEW power supply.

This board manages the display and provides various information regarding equipment installation:

- Manufacturing date
- Serial number
- Software version
- Release date
- Configuration type
- Lamps and bulb holders duration of operation
- Commissioning date
- Current/voltage reading of 2 voltage controllers.
- Current/voltage reading of battery charge + discharge current
- Manages the By-pass control.
- Manages Mains Power Cut.
- Manages inhibition of controllers and the charger.
- Manages lighting adjustment of lamps using the information from the Lexan panel.
- Manages the battery charge.
- Manages lamp faults
- Manages the service life of lamps + Bulb holder + battery via the display
- Manages the number of switches to battery (Supply fault)
- Manages the frequency of service visits
- The management board provides information on an LCD display on the front panel of the box. The display of the settings comes up when the push button is pressed on the μ C board. There is an RS 232 output via a 3-pin Wagon connector. This option uses a communication protocol to allow Inputs/Outputs information to go to a PC. It enables the transfer of messages from the display and the control of lighting commands.

Mechanics

- Bare PCB on aluminium plate
- Format 290 x 62 x 32 mm
- Fastened onto the right of the case by two 4 mm screws
- Connection: Through plate coils and connectors with controller boards and a charger. Connected to the Lexan panel controls and display by 8-pin RJ 45 cables.

Thermal

- Ambient operating temperature -0°C to +40°C
- Storage temperature -25 to +70°C

SPECIFICATIONS OF THE LEXAN INTERFACE PANEL

Function

- This indicates the illumination level per 4 LEDs. There are eight illumination levels (1 low + 1 high). Indicates the discharge level of the batteries. increment illumination + or – using the keys.
- ON/OFF function using the keys
- Battery version
- Green LED = Mains presence
- Red LED for the batteries
- Yellow flashing LED to show that a bulb has blown.
- Steady yellow LED to show any other fault (see display).
- The flashing LED shows the charge level while the battery is charging. The bottom LEDs have a steady light.
- Bottom LED flashing = battery flat
- Top LED flashing = battery charged.
- Daily backup test: Keep the ON button down for two seconds to start a test that switches to batteries for 3 seconds. The system automatically returns to normal operation

Mechanics

- Steel plate bracket or mosaic panel
- Format 45 x 45 x 50 mm
- Attached to front plate or mosaic panel enclosure.
- Connected by an 8-pin RJ 45 connector cable.

Thermal

- Ambient operating temperature -0°C to $+40^{\circ}\text{C}$
- Storage temperature -25 to $+40^{\circ}\text{C}$

BLOCK DIAGRAM

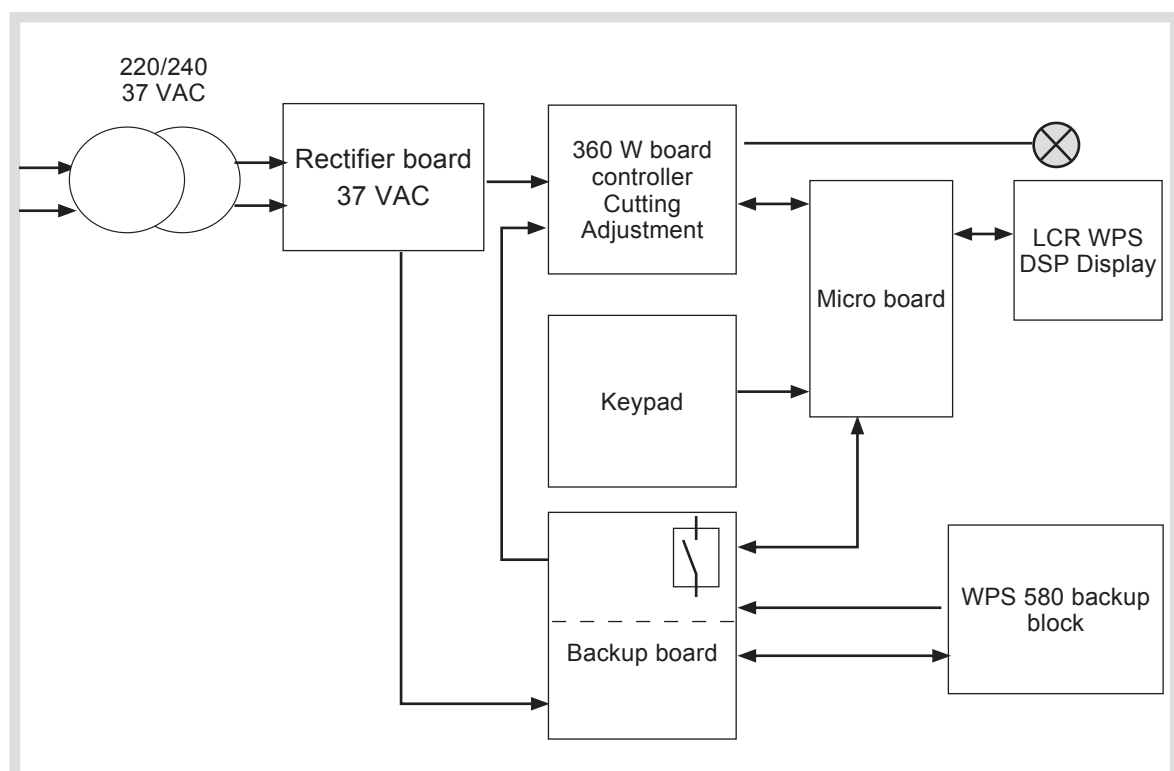

RS 232 PROTOCOL

Communication parameters

Baud = 9600
 Data bits = 8
 Parity = none
 Stop bits = 1
 Flow control = none

Memory	EEPROM			Write memory	WPS response	Read memory	WPS response
				PC -> WPS	WPS -> PC	PC -> WPS	WPS -> PC
0	BULB HOLDER 1	0	4	&06H1xxxx	&1	&03H1?	&06H1xxxx
1	BULB 1	4	4	&06B1xxxx	&1	&03B1?	&06B1xxxx
5	BULB HOLDER 2	8	4	&06H2xxxx	&1	&03H2?	&06H2xxxx
	ANNEE	12	1				
16	CONTRACT	13	1	&03CM1/0	&1	&03 CM?	&03CM1/0
	CONFIGURATION	14	1				
	STATUS	15	1				
8	CONV1 UPDATE	16	8	&10D1xx/xx/xx	&1	&03D1?	&10D1xx/xx/xx
9	CONV2 UPDATE	24	8	&10D2xx/xx/xx	&1	&03D2?	&10D2xx/xx/xx
10	BATT UPDATE	32	8	&10DCxx/xx/xx	&1	&03DC?	&10DCxx/xx/xx
11	MANUFACT	40	8	&10DFxx/xx/xx	&1	&03DF?	&10DFxx/xx/xx
12	DEVICE UPDATE	48	8	&10DWxx/xx/xx	&1	&03DW?	&10DWxx/xx/xx
13	BATT STARTUP	56	8	&10DBxx/xx/xx	&1	&03dB?	&10DBxx/xx/xx
2	MAINTENANCE	64	2	&04MTxx	&1		
7	BLOC BATTERIE	66	1	&03BBx	&1		
3	BATTERY TEST	67	2	&04TBxx	&1		
	START_MAINT	69	3				
	START_BAT_TST	72	3				
			1				
	% CONV1	76	1			&03P1?	&0yP1xxx
	% CONV2	77	1			&03P2?	&0yP2xxx
			2				
	TEMPS_1	80	10			&03R1?	&0yR1=xxxxxx
4	AR	90	6	&08ARxxxxxx	&1	&03AR?	&08ARxxxxxx
	TEMPS_2	96	10			&03R2?	&0yR2=xxxxxx
6	BULB 2	106	4	&06B2xxxx	&1	&03B2?	&06B2xxxx
			2				
	LAST_BAT_CHANGE	112	8			&03DL?	&10DLxx/xx/xx
	BAT_CHANGE_QTY	120	6			&03QC?	&0yQC=xxxxxx
			2				
	ON/OFF coupole 1 &04LX11					ON/OFF coupole 2 &04LX21	
	«+ coupole 1» &04LX12					«+ coupole 2» &04LX22	
	«- coupole 1» &04LX13					«- coupole 2» &04LX23	

If command not understood, the WPS returns nothing or &0

Memory	EEPROM			Write memory	WPS response	Read memory	WSP response
				PC -> WPS	WPS -> PC	PC -> WPS	WPS -> PC
14	HEURE DU JOUR	130	8	&10DHxx/xx/xx	&1	&03DH?	&10DHxx/xx/xx
15	DATE DU JOUR	140	8	&10DTxx/xx/xx	&1	&03DT?	&10DTxx/xx/xx
	VERSION					&04VER?	&07VERx.xx
	T°C					&03TC?	&0yTC=xxx
	T°C max					&04TCX?	&0yTCX=xxx
	Vin					&03VI?	&0yVI=xxx
	Vinmax					&04VIX?	&0yVIX=xxx
	Vs1					&03V1?	&0yV1=xxx
	Vs1max					&04V1X?	&0yV1X=xxx
	Vs2					&03V2?	&0yV2=xxx
	Vs2max					&04V2X?	&0yV2X=xxx
	i1					&03I1?	&0yI1=xxx
	i2					&03I2?	&0yI2X=xxx
	icharge					&03IC?	&0yIC=xxx
	idécharge					&03ID?	&0yID=xxx
	vbat					&03VB?	&0yVB=xxx
	_holder1					&03S1?	&0yS1=xxxx
	_holder2					&03S2?	&0yS2=xxxx
	_bulb1					&03E1?	&0yE1=xxxx
	_bulb2					&03E2?	&0yE2=xxxx
	CONFIG_B1					&05CFG1?	&09CFG1=xxxW
	CONFIG_B2					&05CFG2?	&09CFG2=xxxW
	NIVEAU 1					&03N1?	&04N1=x
	NIVEAU 2					&03N2?	&04N2=x
	ON/OFF coupole 1 &04LX11						ON/OFF coupole 2 &04LX21
	«+ coupole 1» &04LX12						«+ coupole 2» &04LX22
	«- coupole 1» &04LX13						«- coupole 2» &04LX23

If command not understood, the WPS returns nothing or &0

lighthead ON/OFF/cupola/Schale 1	&04LX11	lighthead ON/OFF/cupola/Schale 2	&04LX21
"+ lighthead/cupola/Schale 1"	&04LX12	"+ lighthead/cupola/Schale 2"	&04LX22
"- lighthead/cupola/Schale 1"	&04LX13	"- lighthead/cupola/Schale 2"	&04LX23

If command not understood, the WPS returns nothing or &0I

11.3 ADJUSTMENT

The voltage or current may be adjusted and with or without the WPS TEST test box. We recommend you however to purchase the test box, as it will make adjusting that much easier.

ADJUSTMENT FOR THE WPS NEW MODULE

If you are configuring and installing a surface-mounted WPS NEW case in the room, the settings can be adjusted directly from the control pad and you will see the information appear on the digital display.

Procedure

- Place your multimeter on the AV+DC voltmeter setting it across the terminals of the bulb holder.
- Turn the potentiometer setting of the controller card up until you reach the recommended value.
- Repeat the same process for the other lighthead.

ADJUSTMENT USING THE WPS TEST TEST BOX:

If you are configuring the remote control you can do the settings directly in the WPS NEW module without connecting to the lamp terminals. Since you do not have a digital screen and control button for remote controls, you need to use the WPS TEST test box.

Procedure

- Connect the test box to the location of the Lexan panel (control keypad) and the display
- Turn on the lighthead running at maximum illumination
- Press the white button on the controller board
- Display the voltage/current settings using the ON/OFF key
- Refer to the table on the next page to adjust the output voltage/current with the potentiometer.

SUMMARY TABLE OF ADJUSTMENT VALUES

Total P (bulb W)	250
Number of bulbs	2 x 100
Operating voltage	23.5 V +0.5
Current used	8 A

11.4 NAVIGATION IN MENUS AND ADJUSTING SETTINGS

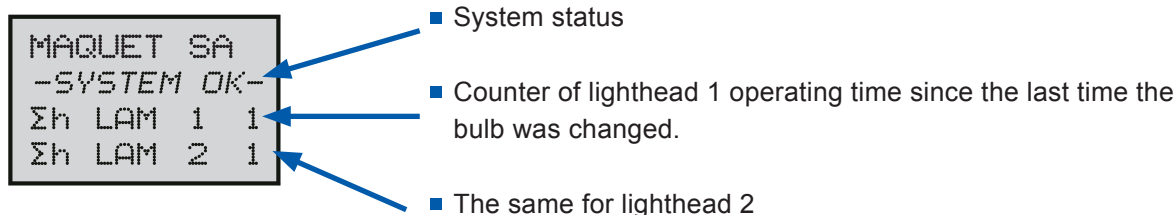

Message on screen	Cause	Corrective action
LAM 1 CHANGE	<ul style="list-style-type: none"> Bulb in lighthouse 1 burnt out or terminal count on bulb counter reached 	<ul style="list-style-type: none"> Change the bulbs in lighthouse 1
LAM 2 CHANGE	<ul style="list-style-type: none"> Bulb in lighthouse 2 burnt out or terminal count on bulb counter reached 	<ul style="list-style-type: none"> Change the bulbs in lighthouse 2
L1 SUP. CHANGE	<ul style="list-style-type: none"> Terminal count on lighthouse 1 bulb holder counter reached 	<ul style="list-style-type: none"> Change lighthouse 1 bulb holder
L2 SUP. CHANGE	<ul style="list-style-type: none"> Terminal count on lighthouse 2 bulb holder counter reached 	<ul style="list-style-type: none"> Change lighthouse 2 bulb holder
CHECK UP BATT.	<ul style="list-style-type: none"> Terminal count on battery test frequency 	<ul style="list-style-type: none"> Test the batteries
CHANGE BATTERY	<ul style="list-style-type: none"> Batteries at end of useful life 	<ul style="list-style-type: none"> Replace the batteries
MAINTENANCE	<ul style="list-style-type: none"> Terminal count on maintenance visit frequency 	<ul style="list-style-type: none"> Call Maquet technical department
SYST. DEFAULT	<ul style="list-style-type: none"> Faulty electrical connection or faulty component 	<ul style="list-style-type: none"> Call Maquet technical department

START UP (LIGHTHEAD OFF)

Display	Menu
MAQUET GETINGE	<ul style="list-style-type: none"> ■ Press the button on the controller board
MENU SELECTION	
START UP <input checked="" type="checkbox"/>	<ul style="list-style-type: none"> ■ Press the button on the controller board.
INFO MODE <input type="checkbox"/>	<ul style="list-style-type: none"> ■ Use the + and - keys on the Lexan panel to select the menu you require.
TEST MODE <input type="checkbox"/>	
SET UP <input type="checkbox"/>	<ul style="list-style-type: none"> ■ To Enter the menu, confirm selection by pressing the 0/1 key ■ Example: Real Clock
SETTING THE TIME	
REAL TIME Time/Date: 11:15:56	<ul style="list-style-type: none"> ■ Press the + button, the cursor moves underneath the first hours digit. ■ Press the + button + or - to move hours up and down. ■ Press the 0/1 key to confirm selection, then selection automatically moves to the date.
SET THE DATE	
REAL TIME Date: 11:15:56 9/18/09	<ul style="list-style-type: none"> ■ Press the + button, the cursor moves underneath the first date digit. ■ Press the + button + or - to move days up or down. ■ Press the 0/1 key to confirm selection. ■ Press the 0/1 key: The lighthouse lights up, display finishes.
MANUFACTURING DATE OF THE POWER SUPPLY	
MAQUET GETINGE PRODUCTION DATE 18/09/09_	<ul style="list-style-type: none"> ■ Not modifiable ■ 0/1
SERIAL NUMBER	
MAQUET GETINGE SERIAL NUMBER AR 000001_	<ul style="list-style-type: none"> ■ Not modifiable ■ 0/1
SOFTWARE VERSION	
MAQUET GETINGE SOFTWARE VERSION V1.01	<ul style="list-style-type: none"> ■ Not modifiable ■ 0/1
COMMISSIONING DATE OF THE POWER SUPPLY	
MAQUET GETINGE WPS Startup Date 12/09/2007_	<ul style="list-style-type: none"> ■ Press the + button, the cursor moves underneath the first date digit. ■ Press the + button + or - to move days up or down. ■ Press the 0/1 key to confirm selection, selection moves to the units digit. ■ 0/1
COMMISSIONING DATE OF BATTERIES	
MAQUET GETINGE BATTERY Startup Date 12/09/2007_	<ul style="list-style-type: none"> ■ Press the + button, the cursor moves underneath the first date digit. ■ Press the + button + or - to move days up or down. ■ Press the 0/1 key to confirm selection, selection moves to the units digit. ■ 0/1
MAQUET GETINGE	<ul style="list-style-type: none"> ■ Finished

INFO MODE (LIGHTHEAD OFF)

Display	Menu
MAQUET GETINGE	■ Press the button on the controller board
MENU SELECTION	
START UP <input type="checkbox"/>	■ Press + to go to INFO MODE.
INFO MODE <input checked="" type="checkbox"/>	■ Press the 0/1 key to confirm selection, and proceed to the next step.
TEST MODE <input type="checkbox"/>	
SET UP <input type="checkbox"/>	■ INFO MODE is a menu for consultation only
COMMISSIONING DATE FOR CONVERTER NO. 1	
INFO CONVERTER 1 Startup Date 12/02/09	■ Press the 0/1 key to confirm selection, and proceed to the next step.
COMMISSIONING DATE FOR CONVERTER NO. 2	
INFO CONVERTER 2 Startup Date 12/02/09	■ Press the 0/1 key to confirm selection, and proceed to the next step.
OPERATING TIME OF CONVERTER NO. 1	
INFO CONVERTER 1 RunTime1 ToT 0 h	■ Press the 0/1 key to confirm selection, and proceed to the next step.
OPERATING TIME OF CONVERTER NO. 2	
INFO CONVERTER 2 RunTime2 ToT 0 h	■ Press the 0/1 key to confirm selection, and proceed to the next step.
% AVERAGE ILLUMINATION	
INFO LUX Startup Date Lux 1 = 25% Lux 2 = 75% lux%	<ul style="list-style-type: none"> ■ Displays customer habits in terms of average lamp power. ■ This description should be used to fine-tune lamp and bulb holder warning signals. ■ Average high value = Average consumables life expectancy + low values. ■ Press the 0/1 key to confirm selection, and proceed to the next step
DATE BATTERY MODE WAS LAST USED	
INFO BATT. SWITCH Last switch 17/09/09	■ Press the 0/1 key to confirm selection, and proceed to the next step.
NUMBER OF TIMES SWITCHED TO BACKUP	
INFO BATT. SWITCH SWITCH QTY 0	■ Press the 0/1 key to confirm selection, and proceed to the next step.

INFO MODE (LIGHTHEAD OFF)

Display	Menu	Message
HOUR COUNTER FOR CONSUMABLES LIGHTHEAD 1 (TIME ELAPSED)		
INFO CUPOLA 1 LSUP = 72 h LAMP = 25 h	■ Press the 0/1 key to confirm selection, and proceed to the next step.	
HOUR COUNTER FOR CONSUMABLES LIGHTHEAD 2 (TIME ELAPSED)		
INFO CUPOLA 2 LSUP = 72 h LAMP = 25 h	■ Press the 0/1 key to confirm selection, and proceed to the next step.	Lamp socket Lamp
MAXIMUM OUTPUT VOLTAGE FOR LIGHTHEAD 1		
INFO CUPOLA 1 VOLT OUT MAX = 26.0V	■ Press the 0/1 key to confirm selection, and proceed to the next step.	
MAXIMUM OUTPUT VOLTAGE FOR LIGHTHEAD 2		
INFO CUPOLA 2 VOLT OUT MAX = 26.0V	■ Press the 0/1 key to confirm selection, and proceed to the next step.	
MAX. TEMPERATURE READING IN THE PSU CASE		
INFO Temperature Max T = 34°C	■ Press the 0/1 key to confirm selection, and proceed to the next step.	
MAX. INPUT VOLTAGE RECORDED AT THE PRIMARY		
INFO Max. input voltage = 234 V	■ Press the 0/1 key to confirm selection, and proceed to the next step.	
OPERATING STATUS OF CONVERTER NO. 1		
INFO STATUS CONVERTER 1 GOOD	■ Press the 0/1 key to confirm selection, and proceed to the next step.	
OPERATING STATUS OF CONVERTER NO. 2		
INFO STATUS CONVERTER 2 GOOD	■ Press the 0/1 key to confirm selection, and proceed to the next step.	
CONFIGURING CONVERTER BOARD NO. 1		
INFO CONFIG. CUPOLA 1 300 W	■ Press the 0/1 key to confirm selection, and proceed to the next step.	GOOD or BAD
CONFIGURING CONVERTER BOARD NO. 2		
INFO CONFIG. CUPOLA 2 100 W	■ Press the 0/1 key to confirm selection, and proceed to the next step.	GOOD or BAD
MAQUET GETINGE	■ Finished	

TEST MODE (LIGHTHEAD OFF)

Display	Menu
MAQUET GETINGE	■ Press the button on the controller board
MENU SELECTION	
START UP <input type="checkbox"/>	■ Immediate inspection and measurement of values.
INFO MODE <input type="checkbox"/>	■ INFO MODE is a menu for consultation only.
TEST MODE <input checked="" type="checkbox"/>	■ Press + to go to TEST MODE.
SET UP <input type="checkbox"/>	■ Press the 0/1 key to confirm selection, and proceed to the next step.
IMMEDIATE TEMPERATURE AND VOLTAGE MEASUREMENT	
TEST TEMP./VOLT IN T = 32 Input voltage= 220 V	■ Press the 0/1 key to confirm selection, and proceed to the next step.
VOLTAGE AND BATTERY CURRENT	
TEST BATTERY Bat V = 0.27 V I bat = 0.0A	■ Press the 0/1 key to confirm selection, and proceed to the next step.
MAQUET GETINGE	■ Finished

SET UP (LIGHTHEAD OFF)

Display	Menu	Message
MAQUET GETINGE	<ul style="list-style-type: none"> ■ Press the button on the controller board 	
MENU SELECTION		
START UP <input type="checkbox"/>	<ul style="list-style-type: none"> ■ Press + to go to SET UP. ■ Press the ON key to confirm selection. 	
INFO MODE <input type="checkbox"/>		
TEST MODE <input type="checkbox"/>		
SET UP <input checked="" type="checkbox"/>		
ADJUST SERVICE LIFE OF THE BULB HOLDER FOR LIGHTHEAD 1		
L1 HOLDER S = 1500	<ul style="list-style-type: none"> ■ Once the timer reaches the setpoint value (in hours), the following message is displayed: ■ Press the + button to move the cursor beneath the thousands digit. ■ Adjust the timer using the + and - keys. ■ Confirm the value with the ON key. ■ Proceed to the hundreds digit. 	L1SUP.CHANGE
ADJUST SERVICE LIFE OF THE BULB FOR LIGHTHEAD 1		
L1 HOLDER S = 1500 LAMP 1 L = 1000_	<ul style="list-style-type: none"> ■ Once the timer reaches the setpoint value (in hours), the following message is displayed: ■ Press the + button to move the cursor beneath the thousands digit. ■ Adjust the timer using the + and - keys. ■ Confirm the value with the ON key. ■ Proceed to the hundreds digit. 	LAMP1 CHANGE
ADJUST SERVICE LIFE OF THE BULB HOLDER FOR LIGHTHEAD 2		
L2 HOLDER S = 1500	<ul style="list-style-type: none"> ■ Once the timer reaches the setpoint value (in hours), the following message is displayed: ■ Press the + button to move the cursor beneath the thousands digit. ■ Adjust the timer using the + and - keys. ■ Confirm the value with the ON key. ■ Proceed to the hundreds digit. 	L2SUP.CHANGE
ADJUST SERVICE LIFE OF THE BULB FOR LIGHTHEAD 2		
L2 HOLDER S = 1500 LAMP 2 L = 1000_	<ul style="list-style-type: none"> ■ Once the timer reaches the setpoint value (in hours), the following message is displayed: ■ Press the + button to move the cursor beneath the thousands digit. ■ Adjust the timer using the + and - keys. ■ Confirm the value with the ON key. ■ Proceed to the hundreds digit. 	LAMP2 CHANGE
FREQUENCY OF SERVICING		
MAINTENANCE M = 12 months	<ul style="list-style-type: none"> ■ After 12 month, the following message is displayed: 	MAINTENANCE
CONFIRMATION OF MAINTENANCE AGREEMENT		
MAINTENANCE M = 12 months CONTRACT? YES - NO	<ul style="list-style-type: none"> ■ If the response is NO, no warning message will be displayed except that there is a bulb failure. 	

REPLACING CONVERTER 1

If converter was replaced during repair work

CONVERTER 1 UPDATE?	■ If the response is yes, the start date of converter 1 is changed to the current date.
------------------------	---

NO - YES

CONVERTER 1 UPDATE?	■ Display
------------------------	-----------

9/18/09

REPLACING CONVERTER 2

If converter was replaced during repair work

CONVERTER 2 UPDATE?	■ If the response is yes, the start date of converter 1 is changed to the current date.
------------------------	---

NO - YES

CONVERTER 2 UPDATE?	■ Display
------------------------	-----------

9/18/09

REPLACING BATTERIES

If the batteries were replaced during repair work

BATTERY UPDATE?	■ If the response is yes, the start date of the batteries is changed to the current date.
--------------------	---

NO - YES

BATTERY UPDATE?	■ Display
--------------------	-----------

9/18/09

FREQUENCY OF BATTERY TESTS

BATTERY TEST TST = 00_days	■ If the batteries are connected, a test may be CHECK UP BATT. scheduled and the following message will be displayed:
-------------------------------	---

BLOCK BATTERY Qty = 1	■ Number of battery packs connected.
--------------------------	--------------------------------------

BATTERY MAQUET	■ Maquet or other batteries.
----------------	------------------------------

YES - NO

AXCEL?	■ If Axcel mode is selected, the bulb failure warning is disabled.
--------	--

YES - NO

VERSION: 110 V	■ Select the appropriate input voltage. This causes the TEST MODE measurements to be initiated.
-------------------	---

11.5 BATTERIES

- YUASA, 12 V, 24 Ah lead batteries manufactured in France.
- NP batteries may be used in all positions except on the underside.
- They are placed in an ABS tray with safety valves for the internal pressure.
- Over 1000 charge and discharge cycles are possible.
- Their service life is approximately 3 years for NP batteries in accordance with Maquet specifications.

Note: The service life is directly influenced by:

- The number of starting cycles,
- The discharge depth (the most significant affecting a battery's service life)
- The ambient temperature,
- Charge voltage.

- A battery's level of self-discharge stands at around 3% per month when the batteries are stored at an ambient temperature of 20°C.
- In general the warmer it is, the less time the batteries remain charged.
- The following are certified or compliant: VDS/IEC056/VDE/UL/IATA/NATO/ISO9002.

Temperature	Storage
0°C - 20°C	12 months
21°C - 30°C	9 months
31°C - 40°C	5 months
1°C - 50°C	2.5 months



WARNING

- Do not place a battery next to a device that causes flames or of sparks.
- If a battery is placed in a cupboard or a case, it must be ventilated.
- Store the batteries in a cool and dry location.



RECOMMENDATION

Recycling batteries

- In accordance with article 9 of decree No.97-1328 (30 December 1997), "Users of batteries and accumulators other than for domestic use must collect or have collected, process or have processed, dispose of or have disposed of their used batteries or accumulators".
- This collection can be carried out by ourselves when our technician comes to replace units.

12 TROUBLESHOOTING THE WPS

Problem	Check	Corrective action
<ul style="list-style-type: none"> The surgical light does not work. 	<ul style="list-style-type: none"> The light is off. 	<ul style="list-style-type: none"> Briefly press the ON/OFF button.
	<ul style="list-style-type: none"> Check that the bulb holder is in place. 	<ul style="list-style-type: none"> Install the bulb holder correctly.
	<ul style="list-style-type: none"> Check the electrical continuity by checking the regular bulb output (the faulty bulb indicator light should be on if there is no continuity). 	<ul style="list-style-type: none"> Using an ohmmeter, test the continuity until the faulty bulb operates correctly again.
	<ul style="list-style-type: none"> If the backup board is not installed, make sure that the blade connector fastening the red cable to the terminal strip on the regulator board is correctly in place on the appropriate terminal. 	<ul style="list-style-type: none"> Place the blade connector on the appropriate terminal.
	<ul style="list-style-type: none"> Make sure that the mains and optional batteries are present. 	<ul style="list-style-type: none"> Turn on the mains and insert the battery fuse.
	<ul style="list-style-type: none"> Make sure that each green LED (correction operation) is lit on each electronic circuit board. 	<ul style="list-style-type: none"> If an LED is off, make sure that power is being supplied to the corresponding board.
	<ul style="list-style-type: none"> Check the condition of all power supply and battery fuses. 	<ul style="list-style-type: none"> Replace the fuses as necessary. Replace the board if the problem persists.
	<ul style="list-style-type: none"> Make sure that the regulator power supply connectors are correctly in place. 	<ul style="list-style-type: none"> Connect the Lexan control keypads, the regulator power supplies, and the interconnection cables.
	<ul style="list-style-type: none"> If a display is present, check whether the SYST.DEFAULT message is on screen. 	<ul style="list-style-type: none"> Using an RJ20R cable, connect a Lexan control keypad directly to a regulator and check whether the problem is resolved.
	<ul style="list-style-type: none"> Check the wiring of the keypads (RJ45 cables). 	<ul style="list-style-type: none"> Check and re-wire the RJ45 connector if necessary.
<ul style="list-style-type: none"> Check the condition of the regulator in the INFO menu (via the SOFTWARE menu). 	<ul style="list-style-type: none"> If a regulator is reported as being 'defective' after carrying out the above procedure, replace the regulator. 	
<ul style="list-style-type: none"> The controller board is still in programming mode following an adjustment or an incorrect operation. 	<ul style="list-style-type: none"> Exit programming mode by pressing the ON/OFF button on the screen as many times as needed. 	

Problem	Check	Corrective action
<ul style="list-style-type: none"> ■ The battery backup does not work 		<ul style="list-style-type: none"> ■ Plug in the fuse of the backup block
	<ul style="list-style-type: none"> ■ Check the polarities of the battery connections 	<ul style="list-style-type: none"> ■ The red terminal of the battery pack must be connected to the red terminal of the connector for the charger/bypass board.
	<ul style="list-style-type: none"> ■ Check the condition of the fuses of the backup card 	<ul style="list-style-type: none"> ■ Change the fuse if necessary
	<ul style="list-style-type: none"> ■ Check that the power supply and interconnection connector is properly in place. 	<ul style="list-style-type: none"> ■ Put the connectors in place.
	<ul style="list-style-type: none"> ■ Check the condition of battery charge using a voltmeter or using the display in test mode 	<ul style="list-style-type: none"> ■ If the batteries produce a voltage less than 20 V, they need to be replaced.
	<ul style="list-style-type: none"> ■ Check that the green indicator of the charger/bypass board is lit ■ Reset the power supply by cutting the network and the battery fuse for 10 seconds 	<ul style="list-style-type: none"> ■ If the indicator is still not lit after all the checks outlined above, then the charger/bypass board need to be replaced.
<ul style="list-style-type: none"> ■ The display is blank. 	<ul style="list-style-type: none"> ■ Make sure that the display cable is properly connected. ■ Remove the protective film from the display. ■ Check whether the green LED is lit on the controller board. ■ Reinitialise the display by turning off the power supply and the batteries for 10 seconds. 	<ul style="list-style-type: none"> ■ Refer to the procedure for installing the RJ45 cable.

Problem	Check	Corrective action
<ul style="list-style-type: none"> ■ The light emitted is very low and/or the illumination level cannot be adjusted. 	<ul style="list-style-type: none"> ■ Make sure that the configuration of the regulator power (jumper) matches the bulb wattage. 	<ul style="list-style-type: none"> ■ Place the power adjustment jumper on the appropriate location.
	<ul style="list-style-type: none"> ■ Make sure that the regulator is connected to light with the corresponding power. 	<ul style="list-style-type: none"> ■ Reverse the wiring of lighthead or install an appropriate power controller. (The 450 VA transformer is limited to an illumination power of 400 W.)
	<ul style="list-style-type: none"> ■ Check the wiring and operation of the Lexan keypad. 	
	<ul style="list-style-type: none"> ■ Check the operation of the controller board. 	<ul style="list-style-type: none"> ■ Press the white button of the controller board: If nothing is showing on the display, it is possible that the program has hung or that the electronics of the controller board are faulty. ■ If this is the case, the controller board can be turned off by connecting the Lexan keypads directly to the regulators. Disconnect all the ribbon cables and interconnection cables from the controller board. ■ If the surgical light operates normally after doing so, replace the controller board.
<ul style="list-style-type: none"> ■ The yellow LED on the front panel flashes. 	<ul style="list-style-type: none"> ■ Electrical discontinuity. 	<ul style="list-style-type: none"> ■ Check the wiring and for any loose connections.
	<ul style="list-style-type: none"> ■ Bulb faulty. 	<ul style="list-style-type: none"> ■ Replace the bulb.
<ul style="list-style-type: none"> ■ The yellow LED on the front panel is lit steady. 	<ul style="list-style-type: none"> ■ The system has detected a problem. Call the technical department. 	<ul style="list-style-type: none"> ■ Refer to the information on the screen.

Message on screen	Cause	Corrective action
LAM 1 CHANGE	Bulb in lighthouse 1 burnt out or terminal count on bulb counter reached	Change the bulbs in lighthouse 1
LAM 2 CHANGE	Bulb in lighthouse 2 burnt out or terminal count on bulb counter reached	Change the bulbs in lighthouse 2
L1 SUP. CHANGE	Terminal count on lighthouse 1 bulb holder counter reached	Change lighthouse 1 bulb holder
L2 SUP. CHANGE	Terminal count on lighthouse 2 bulb holder counter reached	Change lighthouse 2 bulb holder
CHECK UP BATT.	Terminal count on battery test frequency	Test the batteries
CHANGE BATTERY	Batteries at end of useful life	Replace the batteries
MAINTENANCE	Terminal count on maintenance visit frequency	<ul style="list-style-type: none"> ■ Call Maquet technical department
SYST. FAULT	Faulty electrical connection or faulty component	<ul style="list-style-type: none"> ■ Call Maquet technical department

CHECKLIST

RETAIN THIS COPY

SERVICE PROTOCOL	
For use during Installation / Servicing	
<h1 style="margin: 0;">X'Ten</h1>	<input type="checkbox"/> Contract Order n°..... <input type="checkbox"/> Chargeable <input type="checkbox"/> Other:.....
<input type="checkbox"/> Installation Delivery date: Installation date: Commissioning date:	
<input type="checkbox"/> Servicing Preventive / Curative Valid until:	
Hospital:	
Building:	Floor level:
Service:	Operating room:
Product(s) identification	
Cupola n°1	Ref. number: S/N:
Cupola n°2	Ref. number: S/N:
Cupola n°3	Ref. number: S/N:
Overall assessment	
<input type="checkbox"/> Configuration fully operational	
<input type="checkbox"/> Configuration shall not be used until all deficiencies are corrected	
<input type="checkbox"/> Free of direct risk but deficiencies detected. May be corrected on short term.	
<input type="checkbox"/> Configuration no longer safe. Taking out of service is recommended.	
Remarks	
.....	
Signature	
Name: Date:	Name: Function:
Installer/Technician authorized by MAQUET	Customer

Measuring equipment used

IEC 62353 compatible control units

Type: **Voltmeter**

S/N:

Calibration valid until:

Type: **Luxmeter**

S/N:

Calibration valid until:

Type: **Megohmmeter**

S/N:

Calibration valid until:

Type:

S/N:

Calibration valid until:

Electrical safety test

The protective earth resistance is to be measured between point **0** and the point **3**

Pass

Fail

Protective earth resistance \leq 300 m Ω

Measured: m Ω

The continuity test is to be performed between point **3** and the point **4**

Pass

Fail

Continuity test

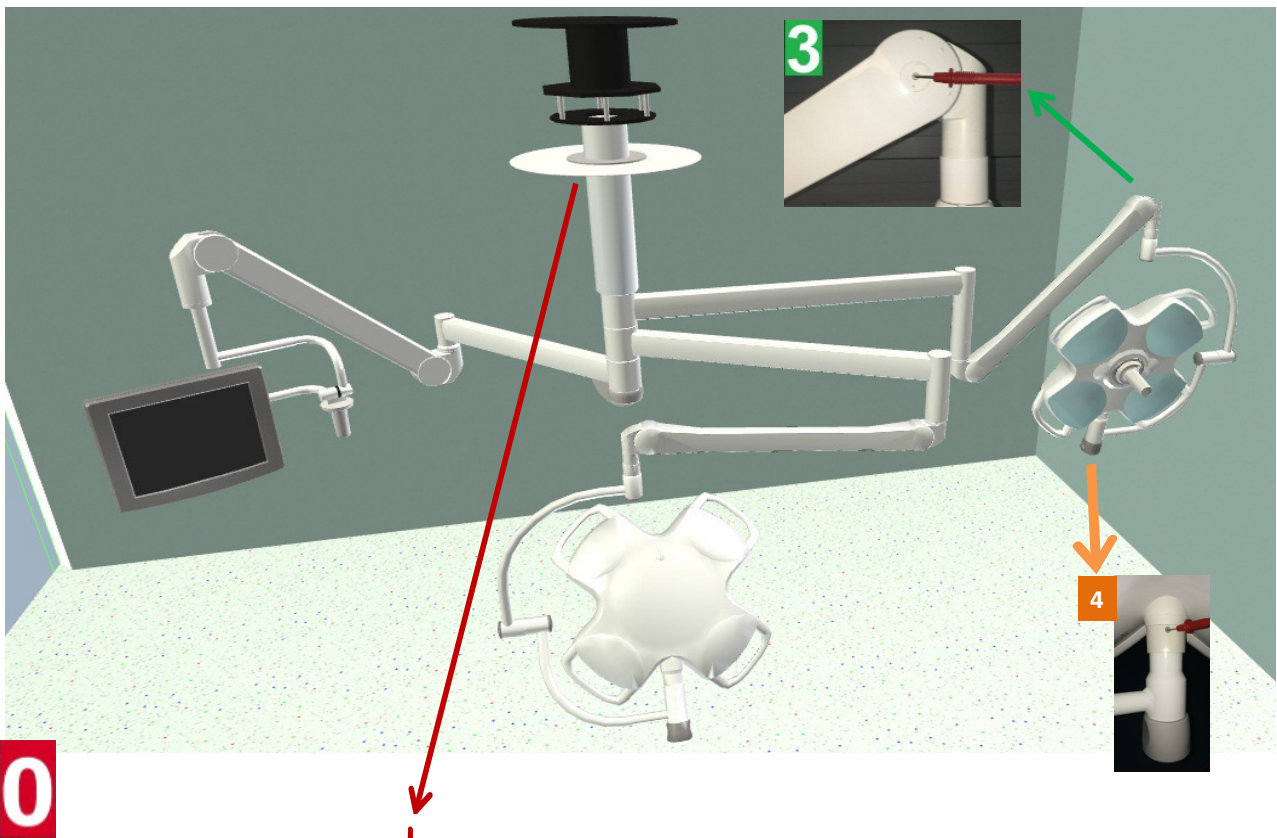

0

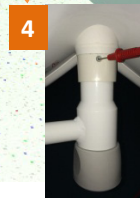

MEASURING POINT DEPENDING OF THE INSTALLATION

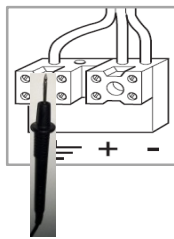

Ensure proper calibration of your measuring equipment before **EACH** reading.

Installation

Delivery verification

Pass

Fail

- Delivery complies with Purchase Order
- Installation manual included
- User manual included

Visual inspection

- Rotating contact and circlips
- General aspect and cleanliness
- Anchor bolts properly fitted
- Verticality of the suspension tube
- WPS is connected to the ground
- Check the label bearing the CE marking

Functioning

- Hardness of the suspension by shaking the configuration
- Balance of the compensation arm
- Adjust the brakes
- Sterilizable handle engages correctly and stays in place
- Test the equipment is easy to handle
- Keypad operates correctly
- All LED modules operate correctly

Options

N/A

- Switch over to battery mode and back to mains
- Camera operates correctly (functions and image)
- Flat screen display(s) undamaged and operates correctly.

Remarks

.....

.....

.....

.....

.....

.....

.....

.....

.....

.....

.....

.....

.....

.....

.....

.....

.....

.....

.....

.....

.....

.....

Place sub-assembly stickers here

Please remove the identification sticker from the packaging and place it in one of the below window frame.

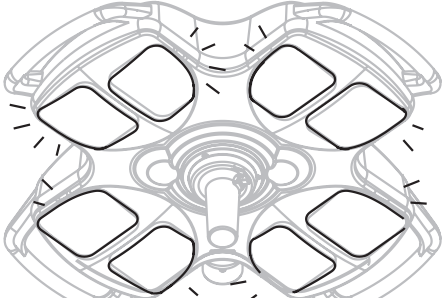
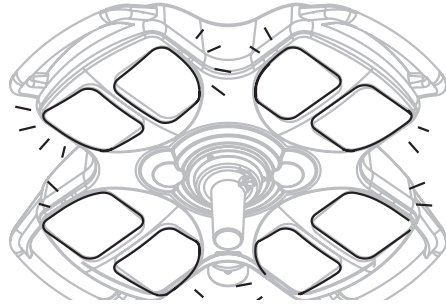
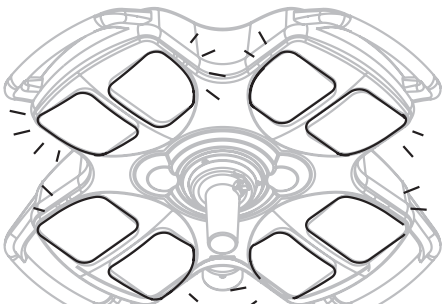
<p>Cupola 1 with S/N</p> 	<p>Cupola 2 with S/N</p> 
<p>Cupola 3 with S/N</p> 	

Note: if applicable, please staple the delivery note with this document.

Maintenance

- | | |
|--|-------------|
| <input type="checkbox"/> Replacement of : | S/N : |
| <input type="checkbox"/> Replacement of : | S/N : |
| <input type="checkbox"/> Replacement of : | S/N : |
| <input type="checkbox"/> MAQUET batteries replaced | |

Remarks

.....

.....

.....

.....

Illumination verification

→ Minimum value : 40 000 lux, maximum value allowed : 160 000 lux

- Using the OPM077, measure the bulb voltage.
 U = 23,5 ± 1V (AC + DC) ou U = 20,8 ± 1V (DC)



U =V

Cupola S/N < 20 000 → 110 000 lux

Cupola S/N > 20 000 → 130 000 lux

- | | | |
|--------------------------|--------------------------|--------------------------|
| N/A | Pass | Fail |
| <input type="checkbox"/> | <input type="checkbox"/> | <input type="checkbox"/> |

Cupola S/N :

Mesuread : lux

- | | | |
|--------------------------|--------------------------|--------------------------|
| <input type="checkbox"/> | <input type="checkbox"/> | <input type="checkbox"/> |
|--------------------------|--------------------------|--------------------------|

Cupola S/N :

Mesuread : lux

- | | | |
|--------------------------|--------------------------|--------------------------|
| <input type="checkbox"/> | <input type="checkbox"/> | <input type="checkbox"/> |
|--------------------------|--------------------------|--------------------------|

Cupola S/N :

Mesuread : lux



Switching over from ambient / main illumination

Settings

- Balance of the spring arm
- Vertical stop of the spring arm

⚠ A spring arm wears out in time and should be replaced every 6 years

Replaced? Yes No

- Test the equipment is easy to handle. Set the brake if necessary

Checkings

- Hardness of the suspension by shaking the configuration
- Verticality of the suspension tube
- 6 fixing screws pre-glued (refer to the appendix in the Technical Manual)
- Fixing of the plastic covers on the spring arm
- Fixing and proper movement of the shutters
- Safety segment present and positioned correctly (dismantle and lubricate if necessary)

Yes No

⚠ A safety segment wears out in time and should be replaced every 2 years. Replaced ?

- Safety sleeve present and positioned with its fixing screw
- Assembly of the joints for each arm. Tightening of the screw and positioning of the retaining ring
- N/A Sterilizable handle holder
- Sterilizable handle engages correctly and stays in place
- Fixing of the outer handles
- Remove the fork bumper rubber cap and check the tightening of the nylong stop.
- Limit stop on the yoke for the cupola rotation is functional
- N/A Keypad operates correctly
- System switches to battery mode and the ON/OFF button LED on the keypad turns orange and switches back to mains
- N/A Opening and closing of the lamp cover
- Replace the 2 bulb holders
- Replace the 2 bulbs
- N/A Light patch, adjusting the mirrors if necessary
- Camera operates correctly (image and functions)
- WPS is connected to the ground
- All boards are properly fixed inside the WPS
- N/A The correct setting on the regulator boards respective to the cupola
- Software version in START UP menu. If inferior to V5.40 → obsolete, inform the customer
- Front pivot on Acrobat 2000 spring arm (see NIT 205 for more details)



Change spring arm if any sign of crack is seen.

Replaced ? Yes No

Tightening

- Collar around the power supply connector at the ceiling tube
- Wires on the power supply connector at the ceiling tube
- Ceiling covers + proper positioning
- Wires on the connectors' terminal heads inside the WPS
- Wires on the battery pack
- All visible screws
- Presence of the stopper on the concerned suspension

Appearance

- All seals hold correctly and are not worn
- General appearance of the underside (no scratches, no cracks)
- No corrosion anywhere
- No paint chip anywhere
- Appearance of the keypad
- Attachment of the WPS on the wall
- Appearance of the WPS cover
- Holding of the cover and the hinges of the WPS
- Cleaning the complete configuration
- Check the label bearing the CE marking



We do not recommend the use of alcoholized solution

CHECKLIST

RETURN THIS COPY
TO YOUR MAQUET DISTRIBUTOR

SERVICE PROTOCOL	
For use during Installation / Servicing	
	<input type="checkbox"/> Contract Order n° <input type="checkbox"/> Chargeable <input type="checkbox"/> Other:
<input type="checkbox"/> Installation Delivery date: Installation date: Commissioning date:	
<input type="checkbox"/> Servicing Preventive / Curative Valid until:	
Hospital:	
Building:	Floor level:
Service:	Operating room:
Product(s) identification	
Cupola n°1	Ref. number: S/N:
Cupola n°2	Ref. number: S/N:
Cupola n°3	Ref. number: S/N:
Overall assessment	
<input type="checkbox"/> Configuration fully operational	
<input type="checkbox"/> Configuration shall not be used until all deficiencies are corrected	
<input type="checkbox"/> Free of direct risk but deficiencies detected. May be corrected on short term.	
<input type="checkbox"/> Configuration no longer safe. Taking out of service is recommended.	
Remarks	
.....	
Signature	
Name: Date:	Name: Function:
Installer/Technician authorized by MAQUET	Customer

Measuring equipment used

IEC 62353 compatible control units

Type: **Voltmeter**

S/N:

Calibration valid until:

Type: **Luxmeter**

S/N:

Calibration valid until:

Type: **Megohmmeter**

S/N:

Calibration valid until:

Type:

S/N:

Calibration valid until:

Electrical safety test

The protective earth resistance is to be measured between point **0** and the point **3**

Pass

Fail

Protective earth resistance $\leq 300 \text{ m}\Omega$

Measured: $\text{m}\Omega$

The continuity test is to be performed between point **3** and the point **4**

Pass

Fail

Continuity test

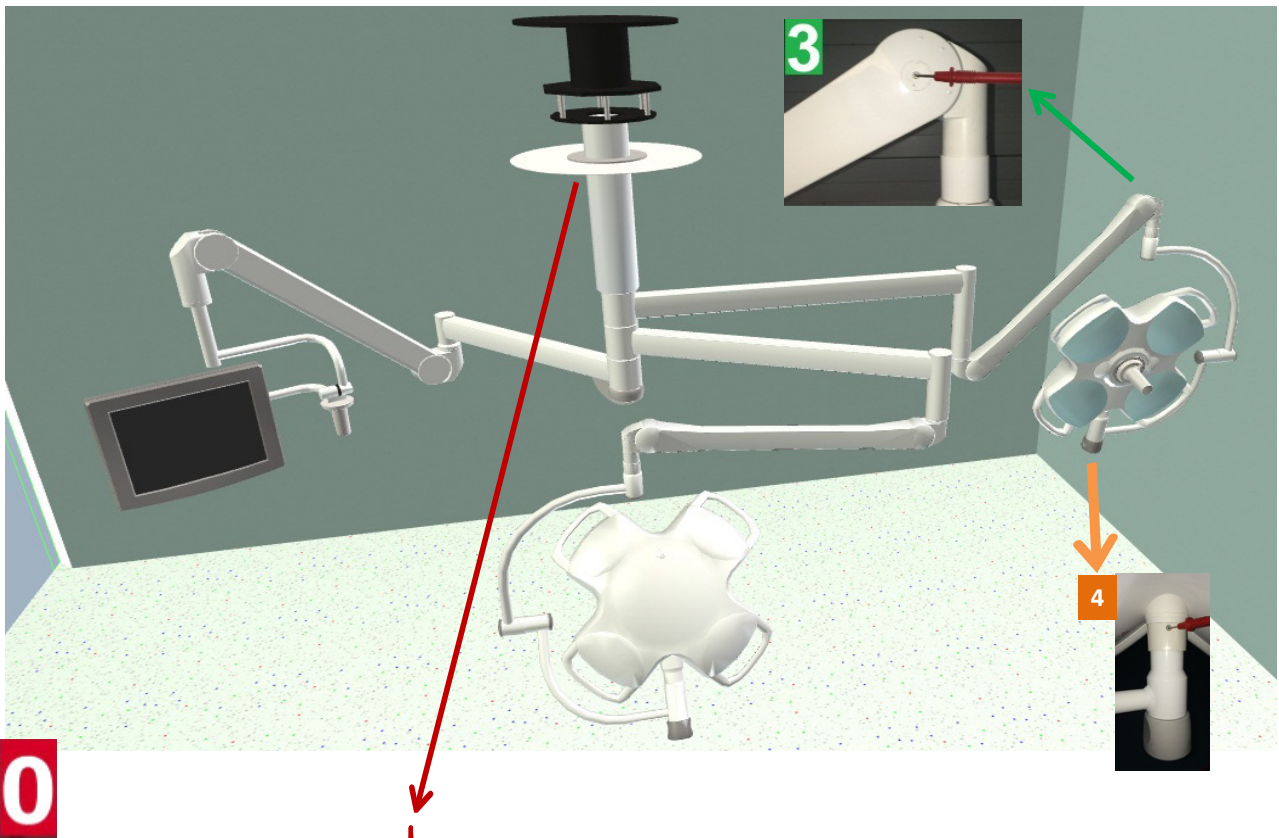

0

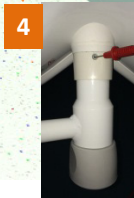

MEASURING POINT DEPENDING OF THE INSTALLATION

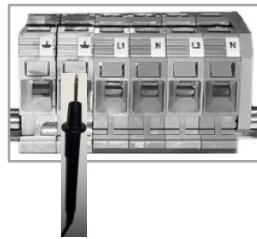
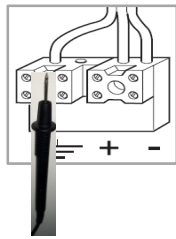

Ensure proper calibration of your measuring equipment before **EACH** reading.

Installation

Delivery verification

Pass

Fail

- Delivery complies with Purchase Order
- Installation manual included
- User manual included

Visual inspection

- Rotating contact and circlips
- General aspect and cleanliness
- Anchor bolts properly fitted
- Verticality of the suspension tube
- WPS is connected to the ground
- Check the label bearing the CE marking

Functioning

- Hardness of the suspension by shaking the configuration
- Balance of the compensation arm
- Adjust the brakes
- Sterilizable handle engages correctly and stays in place
- Test the equipment is easy to handle
- Keypad operates correctly
- All LED modules operate correctly

Options

N/A

- Switch over to battery mode and back to mains
- Camera operates correctly (functions and image)
- Flat screen display(s) undamaged and operates correctly.

Remarks

.....

.....

.....

.....

.....

.....

.....

.....

.....

.....

.....

Place sub-assembly stickers here

Please remove the identification sticker from the packaging and place it in one of the below window frame.

Cupola 1 with S/N

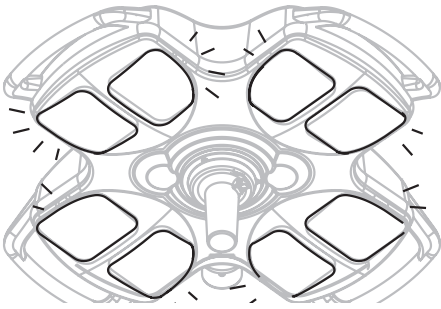

Cupola 2 with S/N

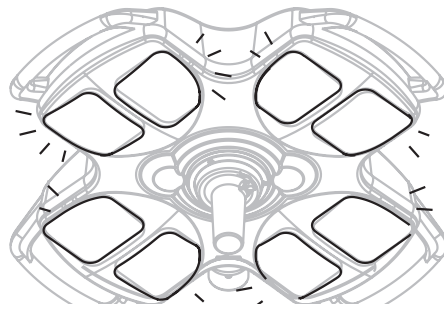

Cupola 3 with S/N

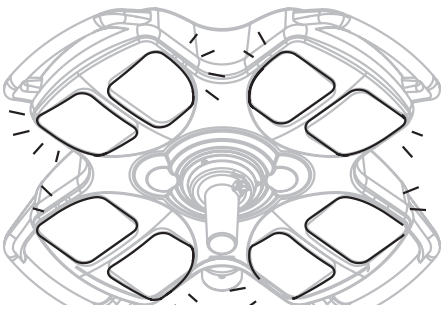

Note: if applicable, please staple the delivery note with this document.

Maintenance

- Replacement of : S/N :
- Replacement of : S/N :
- Replacement of : S/N :
- MAQUET batteries replaced

Remarks

.....

.....

.....

.....

Illumination verification

→ Minimum value : 40 000 lux, maximum value allowed : 160 000 lux

- Using the OPM077, measure the bulb voltage.
U = 23,5 ± 1V (AC + DC) ou U = 20,8 ± 1V (DC)



U =V

Cupola S/N < 20 000 → 110 000 lux

Cupola S/N > 20 000 → 130 000 lux

- N/A
- Pass
- Fail

<input type="checkbox"/>	<input type="checkbox"/>	<input type="checkbox"/>	Cupola S/N :		Mesuread : lux
<input type="checkbox"/>	<input type="checkbox"/>	<input type="checkbox"/>	Cupola S/N :		Mesuread : lux
<input type="checkbox"/>	<input type="checkbox"/>	<input type="checkbox"/>	Cupola S/N :		Mesuread : lux



Switching over from ambient / main illumination

Settings

- Balance of the spring arm
- Vertical stop of the spring arm

⚠ A spring arm wears out in time and should be replaced every 6 years

Replaced? Yes No

- Test the equipment is easy to handle. Set the brake if necessary

Checkings

- Hardness of the suspension by shaking the configuration
- Verticality of the suspension tube
- 6 fixing screws pre-glued (refer to the appendix in the Technical Manual)
- Fixing of the plastic covers on the spring arm
- Fixing and proper movement of the shutters
- Safety segment present and positioned correctly (dismantle and lubricate if necessary)

Yes No

⚠ A safety segment wears out in time and should be replaced every 2 years. Replaced ?

N/A

- Safety sleeve present and positioned with its fixing screw
- Assembly of the joints for each arm. Tightening of the screw and positioning of the retaining ring
- Sterilizable handle holder
- Sterilizable handle engages correctly and stays in place
- Fixing of the outer handles
- Remove the fork bumper rubber cap and check the tightening of the nylong stop.

N/A

- Limit stop on the yoke for the cupola rotation is functional

N/A

- Keypad operates correctly

N/A

- System switches to battery mode and the ON/OFF button LED on the keypad turns orange and switches back to mains

N/A

- Opening and closing of the lamp cover

N/A

- Replace the 2 bulb holders

N/A

- Replace the 2 bulbs

N/A

- Light patch, adjusting the mirrors if necessary

N/A

- Camera operates correctly (image and functions)

- WPS is connected to the ground

- All boards are properly fixed inside the WPS

- The correct setting on the regulator boards respective to the cupola

- Software version in START UP menu. If inferior to V5.40 → obsolete, inform the customer

- Front pivot on Acrobat 2000 spring arm (see NIT 205 for more details)



Yes No

⚠

Change spring arm if any sign of crack is seen.

Replaced ?

Tightening

- Collar around the power supply connector at the ceiling tube
- Wires on the power supply connector at the ceiling tube
- Ceiling covers + proper positioning
- Wires on the connectors' terminal heads inside the WPS
- Wires on the battery pack
- All visible screws
- Presence of the stopper on the concerned suspension

Appearance

- All seals hold correctly and are not worn
- General appearance of the underside (no scratches, no cracks)
- No corrosion anywhere
- No paint chip anywhere
- Appearance of the keypad
- Attachment of the WPS on the wall
- Appearance of the WPS cover
- Holding of the cover and the hinges of the WPS
- Cleaning the complete configuration
- Check the label bearing the CE marking





We do not recommend the use of alcoholized solution

SAFETY PARTS TO BE REPLACED EVERY 6 YEARS

Safety screws:

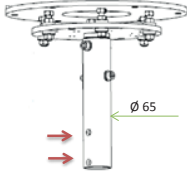
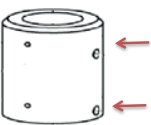
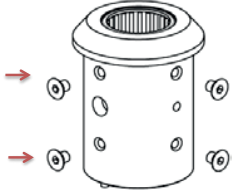
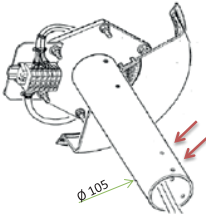
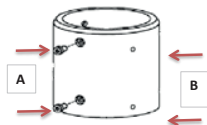
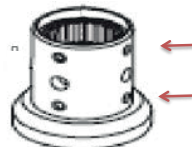
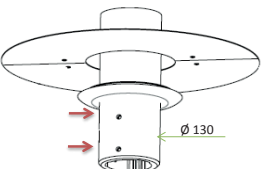
Maquet recommends replacing the safety screws every six years as a precaution.

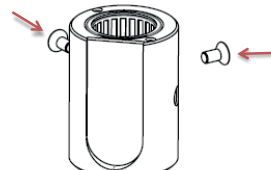
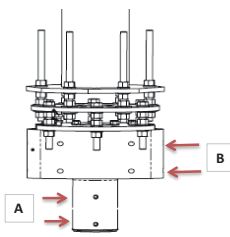
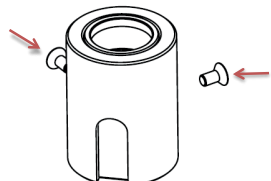
TUBES	ADAPTERS	BUSHINGS
<p>TUB 60</p> <p>SUSP. BLUE 30-80 SUSP. LCA40-50-100 SUSP. VOLISTA ACCESS</p>  <p>Ø 65</p> <p>P/N : ARD36883555 Kit of four pre-glued M6×16 screws</p> <p>⚠ Fastening torque: 17 Nm</p>	<p>ADPT 120 TO 60 ARD515088999</p>  <p>P/N : ARD315027555 Kit of six pre-glued M6×20 low-profile socket head cap screws</p> <p>⚠ Fastening torque: 14 Nm</p>	<p>SA suspension arm cap</p>  <p>P/N : ARD368325556 Kit of four M6×8 socket head countersunk screws</p> <p>⚠ Fastening torque: 7 Nm</p>
<p>ECL</p> <p>SUSP. PRC SUSP. PRX (Avant Sept. 2002)</p>  <p>Ø 105</p> <p>P/N : ARD367014555 Kit of six pre-glued M6×12 socket head cap screws</p> <p>⚠ Fastening torque: 14 Nm</p>	<p>Adapter kit ADAPT KIT HLX2 ARD567914999</p>  <p>A = P/N : ARD315027555 Kit of six pre-glued M6×20 low-profile socket head cap screws</p> <p>B = P/N : ARD367014555 Kit of six pre-glued M6×12 socket head cap screws</p> <p>⚠ Fastening torque: 14 Nm</p> <p>Not sold in the US</p>	<p>SATELITE-OSP suspension arm cap</p>  <p>P/N : ARD315028555 SAT-Kit of four screws for OSP end cap</p> <p>⚠ Fastening torque: 7 Nm</p>
<p>TUB 130 SA suspension PRX suspension (after September 2002)</p>  <p>Ø 130</p> <p>P/N : ARD367270555 Kit of six pre-glued M6×20 (class 10.9) socket head cap screws</p> <p>⚠ Fastening torque: 14 Nm</p>	<p>SA suspension adapter on HANAU CITY tube ARD397807555</p> <p>P/N : ARD397808555 Kit of 12 pre-glued socket head cap screws and socket head countersunk screws</p>  <p>⚠ A : Fastening torque: 14 Nm ⚠ B : Fastening torque: 17 Nm</p> <p>Not sold in the US</p>	<p>ACCESS suspension arm end cap</p>  <p>P/N : ARD368840555 Kit of four pre-glued M6×12 socket head countersunk screws</p> <p>⚠ Fastening torque: 17 Nm</p>
<p>SATELITE Shaft 1: SA suspension Shaft 2: PRX suspension (after September 2002) Shaft 2/3: ARM SAT</p>  <p>A = P/N : ARD315027555 Kit of six pre-glued M6×20 (class 10.9) low-profile socket head cap screws</p> <p>B = P/N : ARD315026555 Kit of six pre-glued M6×25 socket head cap screws</p> <p>⚠ Fastening torque: 14 Nm</p>	<p>LCA DF suspension arm end cap</p>  <p>P/N : ARD368840555 Kit of four pre-glued M6×12 socket head countersunk screws</p> <p>⚠ Fastening torque: 17 Nm</p>	

CLEAN THE SHAFTS AND JOINTS USING A CLEAN CLOTH BEFORE APPLYING GREASE



Cleaner / degreaser

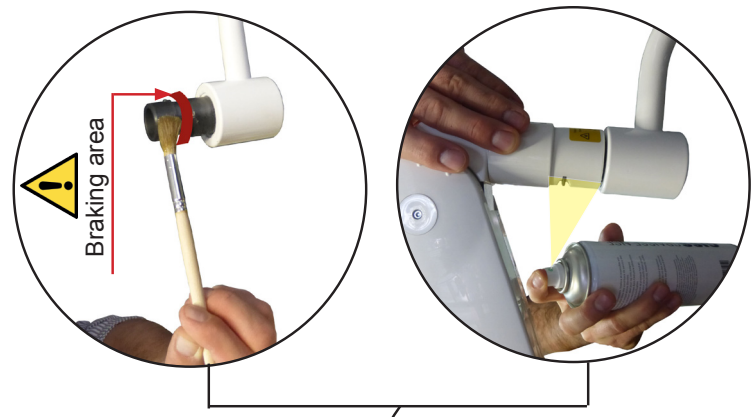
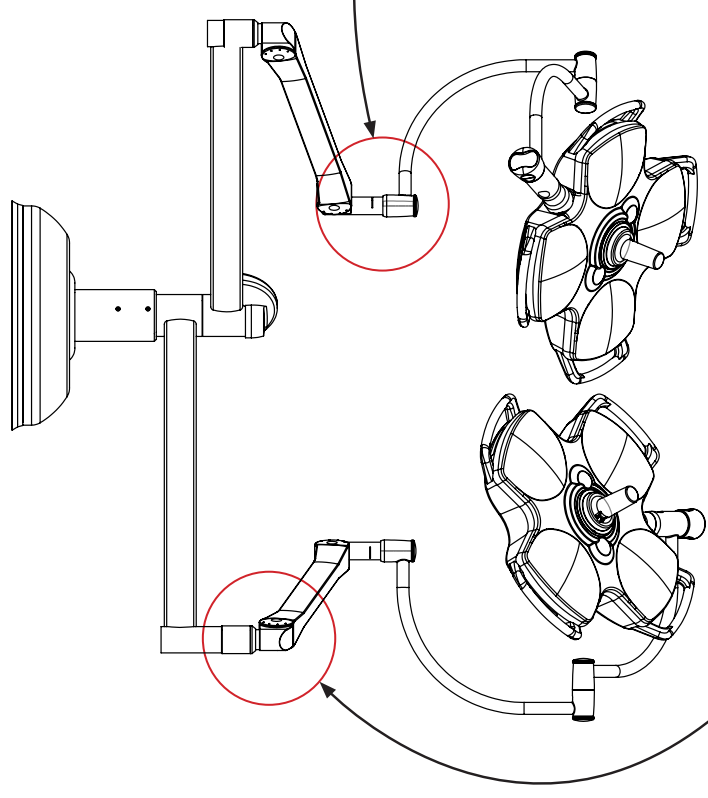

GREASES USED



**REMOVE EXCESS GREASE USING A CLEAN CLOTH
AVOID GREASING THE BRAKING AREAS**

For example or equivalent grease

Ref. SAV : ARD65900016

MAQUET

GETINGE GROUP

MAQUET SAS
Parc de Limère
Avenue de la Pomme de Pin
CS 10008 ARDON
45074 ORLÉANS CEDEX 2, France
Téléphone : +33 (0) 2 38 25 88 88
Fax : +33 (0) 2 38 25 88 00

Pour votre contact local :
Veuillez visiter notre site
www.maquet.com

Le groupe GETINGE est un leader mondial sur le marché des équipements et des systèmes contribuant à valoriser la qualité et la rentabilité dans le domaine de la santé et des sciences de la vie. Les équipements, les services et les technologies proposés sous les marques ArjoHuntleigh pour tout ce qui concerne la manipulation des patients et l'hygiène, la désinfection, la prévention des thromboses veineuses profondes, les lits médicaux, les lits anti-escarres et le matériel de diagnostic, GETINGE pour tout ce qui concerne la lutte et la prévention des infections au sein des établissements de santé et des sciences de la vie, et MAQUET pour tout ce qui est Surgical Workplaces, Cardiovascular et Critical Care.